



Table of contents

Package Contents.....	2
Getting Started.....	3
ARCHOS Mini-Cam.....	4
ARCHOS Weather Tag.....	6
ARCHOS Movement Tag.....	8
Description of the ARCHOS Smart Home Tablet.....	10
Through the Wizard.....	11
Connecting to a WiFi network.....	12
The ARCHOS Home Interface.....	14
ARCHOS Home - First Time Setup.....	16
Accessories Interface.....	20
Managing Accessories.....	21
Connecting with your Mobile Device.....	24
Programs.....	26
ARCHOS Home Interactions.....	29
The Android™ Interface.....	30
Getting Familiar with Android™.....	34
Troubleshooting.....	36

For more information, please consult the FAQs of your product on www.archos.com. Make sure to read them before considering any product return.



Package Contents

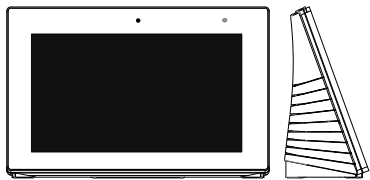

ARCHOS Smart Home Tablet



Mini Cam
X 2



Weather Tag
X 2



Movement Tag
X 2

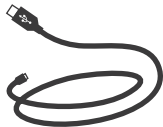

USB cable



Charger



QSG booklet



Warranty,
legal & safety booklet



Getting Started

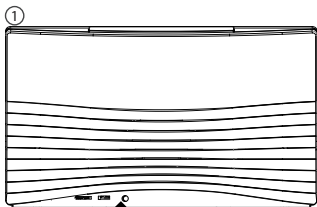

1. Connect your power cable into the power connector.
The Power indicator light is blue when the power cable is plugged in. The device will start charging.

2. Press the ON/OFF button to turn on the device.
- You can use your ARCHOS whilst it charges.
 - Let your device charge completely the first time you use it.
 - Use only the supplied charger.



 **Your device should be connected to the power connector whenever possible.**

TIPS:

To receive more complete service, please register your product.
From a computer, go to www.archos.com/register.



ARCHOS Mini-Cam

Description of the Mini Cam

- ① Pairing button
- ② Pairing indicator
- ③ Camera lens
- ④ Microphone
- ⑤ Sticker

Putting into service the Mini Cam

Your camera functions with 3 Lithium cell CR 24 50 batteries.

1. Unscrew the camera ball.
 2. Remove the insulation label "remove before use".
 3. Screw back up.
 4. Place the camera on its stand.
- Magnets keep it stable. You can move the camera to point in any direction.
5. Remove the sticker on the stand to stick the device to a wall or ceiling.

When you long press the Pairing button (5 seconds)	LED blinks for 60 seconds	The device is in pairing mode and is trying to connect to a tablet.
When you do a short press on the Pairing button	LED blinks for 10 seconds	The device is already paired but is disconnected. It tries to connect.
	LED blinks 3 times	The device is unpaired and disconnected.
	LED is ON for 5 seconds	The device is paired and connected.
	LED blinks fast	An over-the-air update is occurring.

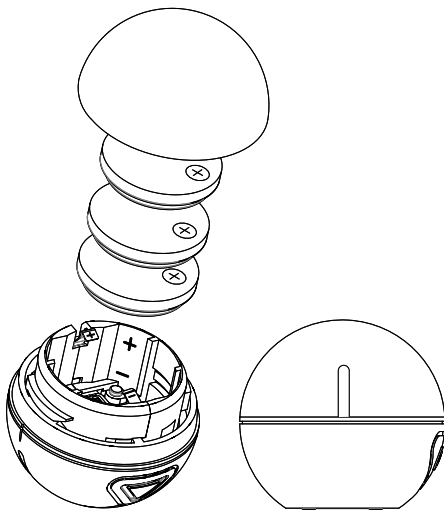
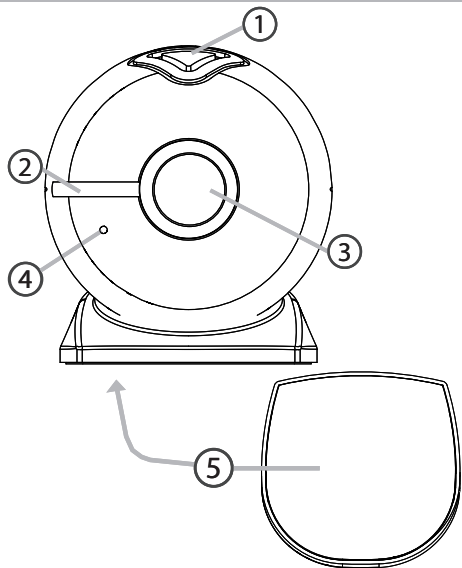



ARCHOS Weather Tag

Description of the Weather tag

- ① Pairing indicator
- ② Pairing button
- ③ Opening
- ④ Sticker

Putting into service the Weather tag

Your Weather Tag functions with a Lithium cell CR 24 30 battery.

1. Remove the rubber case.
2. Detach the top from the back case.
3. Remove the insulation label "remove before use".
4. Replace the back case and rubber.
5. Remove the sticker on the back case to stick the device to a wall.

When you long press the Pairing button (5 seconds)	LED blinks for 60 seconds	The device is in pairing mode and is trying to connect to a tablet.
When you do a short press on the Pairing button	LED blinks for 10 seconds	The device is already paired but is disconnected. It tries to connect.
	LED blinks 3 times	The device is unpaired and disconnected.
	LED is ON for 5 seconds	The device is paired and connected.
	LED blinks fast	An over-the-air update is occurring.

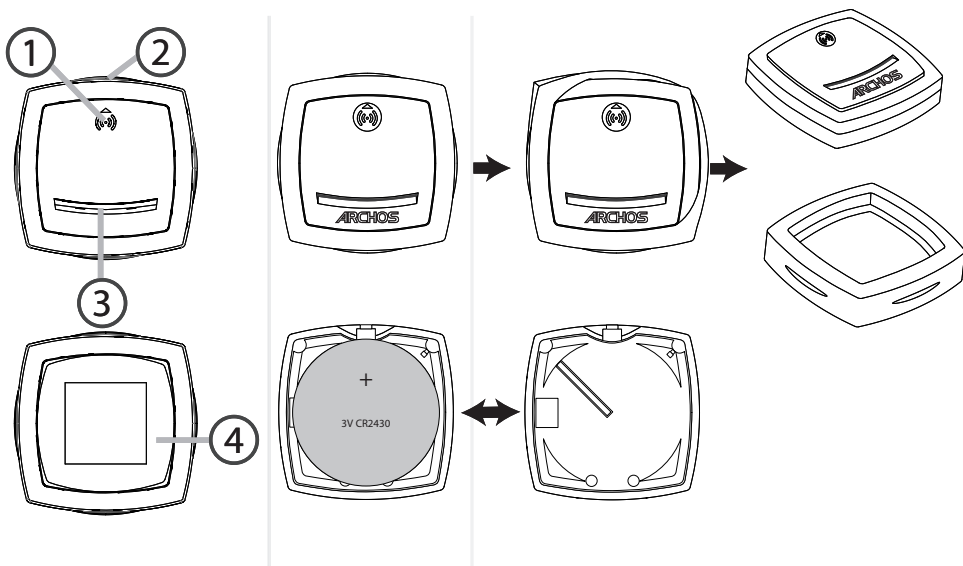



ARCHOS Movement Tag

Description of the Movement tag

- ① Magnet
- ② Magnet sensor
- ③ Magnet sensor indicator
- ④ Pairing button
- ⑤ Pairing indicator
- ⑥ Rubber case
- ⑦ Sticker

Putting into service the Movement tag

Your Movement Tag functions with a Lithium cell CR 24 30 battery.

1. Remove the rubber case of the magnet receiver.
2. Detach the top from the back case.
3. Remove the insulation label "remove before use".
4. Replace the back case.
5. Remove the sticker on the back case to stick the device to a wall.
6. Remove the sticker on the magnet to stick it opposite to the magnet position indicator.

When you long press the Pairing button (5 seconds)	LED blinks for 60 seconds	The device is in pairing mode and is trying to connect to a tablet.
When you do a short press on the Pairing button	LED blinks for 10 seconds	The device is already paired but is disconnected. It tries to connect.
	LED blinks 3 times	The device is unpaired and disconnected.
	LED is ON for 5 seconds	The device is paired and connected.
	LED blinks fast	An over-the-air update is occurring.

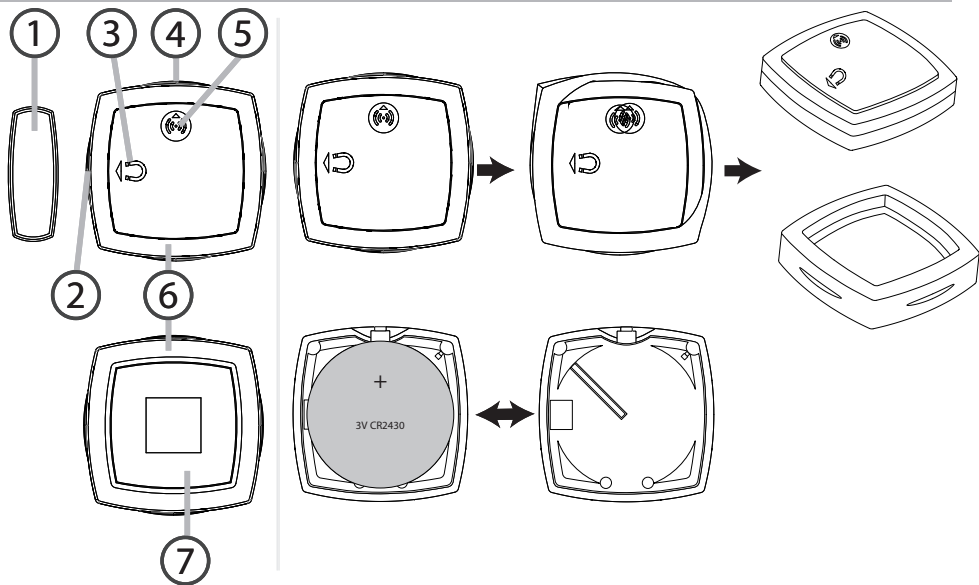



ARCHOS Smart Home Tablet

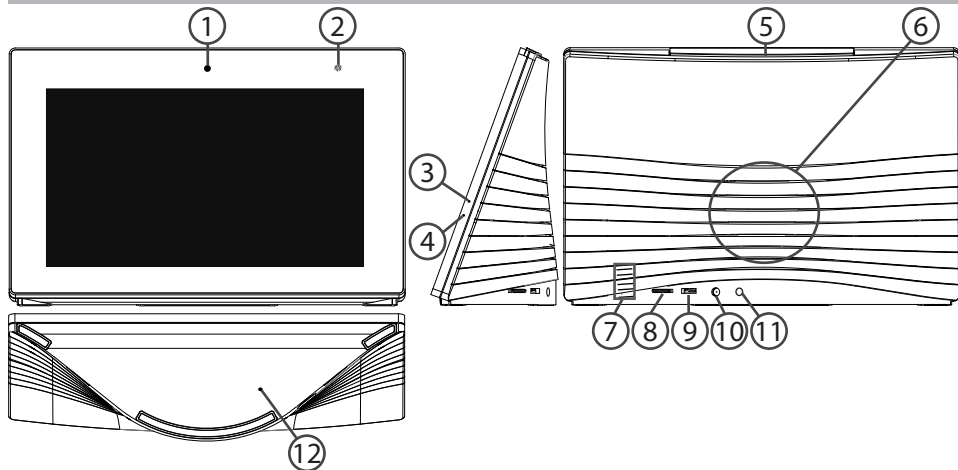

- | | | | |
|----------------------|-----------------|----------------------|-------------------|
| ① Webcam | ④ Microphone | ⑦ Temperature sensor | ⑩ Power connector |
| ② Light sensor | ⑤ ON/OFF button | ⑧ Micro-SD card slot | ⑪ Headphone jack |
| ③ Charging indicator | ⑥ Loudspeaker | ⑨ Micro-USB port | ⑫ Reset button |



Through the Wizard

The first time you start up your ARCHOS, the installation wizard will help you set up your device:

- Language
- WiFi connection
- Google account setup
- Location service options
- 3rd party apps

TIPS:

We recommend that you set up your device in the WiFi zone of the network that you will regularly be using.



Connecting to a WiFi Network

CAUTION: Make sure that you are in a WiFi zone.



① Touch and hold the time & battery icons to reveal the status bar. A blue line is displayed.



② Pull the blue line down to display the status dashboard.



③ Touch "WiFi off" in the status dashboard. The WiFi page will be displayed.



④ Slide the WiFi switch to "ON" position.

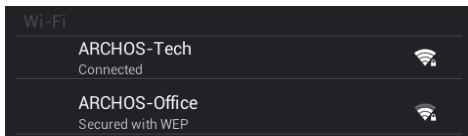

⑤ The ARCHOS will scan for Wifi networks in range. Touch the name of network you want to connect to.

Private networks are shown with a lock icon and will require you to enter your password.



Quick connection

You can connect to your WiFi network through WiFi Protected Setup.

Press the WiFi Protected Setup button on your router. It may be called "WPS" or contain this symbol:

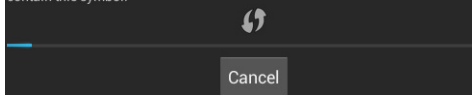

- ① Press the WiFi Protected Setup button  in Settings > Wireless & networks.
- ② In your Internet router, Press the WiFi Protected Setup button called WPS or containing the symbol .

TIPS:

- When entering a WiFi password, we recommend that you select "Show password" so you can see the characters you are typing. To get the correct WiFi password (or settings) for the network, contact the WiFi network provider. If your WiFi is on and you are in range of a network that you previously connected to, your ARCHOS will automatically attempt to connect to it.
- To keep your WiFi connection ON when the device is on sleep, select the Menu icon in the "WiFi" page. Then, select Advanced > Keep WiFi on during sleep > Always.

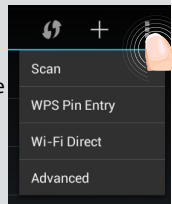



The ARCHOS HOME Interface

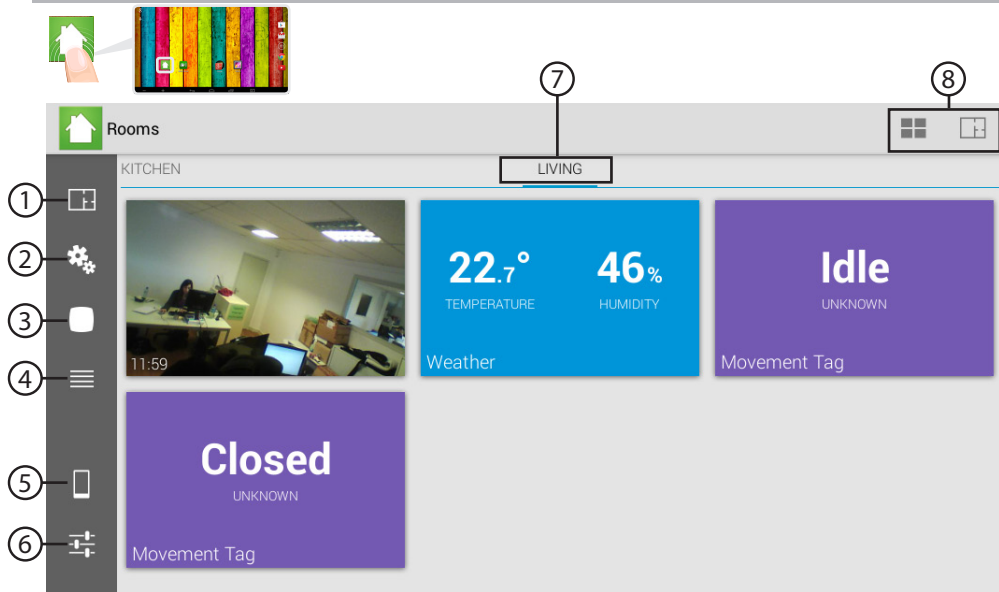



-
- ① **Rooms tab:**
displays the rooms you have created to match the rooms of your house.
 - ② **Programs tab:**
displays the programs created with the paired objects.
 - ③ **All accessories tab:**
displays all the accessories paired with the Archos Smart Home Tablet.
 - ④ **History tab:**
displays the history of actions from the different accessories.
 - ⑤ **Connection tab:**
allows you to connect devices and manage the home tablet from a distance.
 - ⑥ **General tab:**
allows you to add notification accounts and manage settings.
 - ⑦ **Room displayed:**
displays the accessories placed in that room. Slide right to display other rooms.
 - ⑧ **Menu bar:**
displays contextual menu buttons according to the tab.



ARCHOS HOME - First Time Setup

The first time you launch the app, you will need to create rooms. The rooms you create should match the actual rooms where the accessories are placed.

ROOMS

To create a room	
1	Launch the Archos Home app.
2	Select Add a room.
3	Type in a name for the room and select OK.
You can create as many rooms as you want.	
4	When your have finished, select Done.

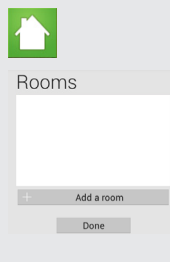



PAIRING

Once you have created rooms, the next step allows you to pair accessories with your tablet.

To pair an accessory

1 Check if Bluetooth is turned ON in the tablet. If not, restart it from Settings > Wireless & Networks.

2 Select the desired accessory.

Make sure you have removed the insulation label "remove before use" in the batteries.

3 Press the pairing button of the accessory for 5 seconds.

The pairing indicator starts blinking.

4 Press the Start button on the tablet.

The pairing process begins.

If the pairing succeeds, the following message is displayed: **Successfully paired! Press OK to continue**

Successfully paired!
Press OK to continue

5 Select OK.

You are offered to link the device with an existing room.



ARCHOS HOME - First Time Setup

If the pairing process fails, you have the following message:

Timeout
Press Cancel to continue

Is Bluetooth turned ON in the tablet?

- 1 Select the Settings app on the tablet.
- 2 In the Wireless & networks section, restart Bluetooth.

Is the pairing indicator of the accessory blinking?

To turn it on, hold the pairing button of the accessory for 5 seconds.

You should restart the pairing.

TIPS:

When you long press the Pairing button (5 seconds)

LED blinks for 60 seconds: The device is in pairing mode and is trying to connect to a tablet.

When you do a short press on the Pairing button

LED blinks for 10 seconds: The device is already paired but is disconnected. It tries to connect.

LED blinks 3 times: The device is unpaired and disconnected.

LED is ON for 5 seconds: The device is paired and connected.

LED blinks fast: An over-the-air update is occurring.



NAMING

After the pairing, you need to type in a name for the accessory.

To name an accessory

1 Type in a name corresponding to the accessory.

You should choose a name that helps you identify easily the accessory and its position in your house.

2 Select OK.

LINKING

After the naming, you can select rooms in which you want to display the device.

To link an accessory to a room

1 Check the chosen room(s).

2 Select Done.

When you have finished the setup, your accessories are displayed in the All accessories tab.





Accessories Interface

All accessories tab

All accessories Sort by room Bluetooth +



① Living ②

 CamBall Mini-Cam ③ 39% Online ⑤ Living	① Name of the section
 Movement Tag Movement Tag ③ 90% Online Living	② Type of sort
 Weather Weather Tag ③ 92% Online Living	③ Bluetooth connection quality
	④ Adding more accessories
	⑤ <ul style="list-style-type: none">- Battery level- Connection status- Room in which it is



Managing accessories



How can I create more rooms?

- 1 In the Archos Home app, select the Rooms section .
- 2 In the Rooms section, select the Rooms icon  in the menu bar.
- 3 Select Add a room and type in the name of the room.
Select Done if you have finished.

Rooms





How can I modify an already created room?

- 1 In the Archos Home app, select the Rooms section .
- 2 In the Rooms section, select the  icon in the menu bar.
- 3 Besides the name of each existing room, select  to modify or delete the room.
- 4 Select Done if you have finished.



Managing accessories

How can I pair more accessories?

- 1 In the Archos Home app, select the All accessories section .
- 2 In the All accessories section, select the  icon in the menu bar.
- 3 Select the type of accessory you want to pair with the tablet.

Make sure you have removed the insulation label “remove before use” in the batteries.

- 4 Press the pairing button of the accessory for 5 seconds.

The pairing indicator starts blinking.

- 5 Press the Start button on the tablet.

The pairing process begins.

Select OK if it succeeds or restart if it fails. See previous accessories section.

All accessories 



Accessories

Click on the accessory type you want to pair





How can I rename an accessory?



- 1 In the Archos Home app, select the All accessories section .
- 2 In the All accessories section, select the accessory  to be renamed.

A list of options is displayed.

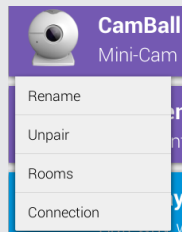
- 3 Select Rename, then OK.



How can I link an accessory to a room?

- 1 In the Archos Home app, select the All accessories section .
- 2 In the All accessories section, select the accessory  to be renamed.

A list of options is displayed.

- 3 Select "Rooms".
- 4 Select the desired room(s), then OK.

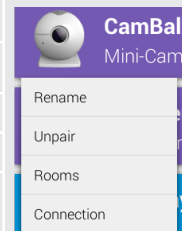



Connecting with your Mobile Device

You can manage your Archos Smart Home Tablet when not at home using a phone or tablet.

Downloading the app

- 1 Download the Archos Home app from Play Store or Appstore or flash the QR Code on the box.
- 2 After the download, launch the application.

The first time you launch the application, you have two options to connect to your Archos Smart Home Tablet.

Connecting when on the same WiFi network

- 1 Select the option **“if you are on the same home network than the Archos Home Gateway”**.



The message **“Looking for the Archos Home Gateways in your local network”** is displayed. Once a Archos Home tablet is found on your network, it is displayed.

- 2 Press to connect.



A Pairing request is sent to the Home Tablet.

- 3 Select **Allow** on the Home Tablet to authorize the device.



The connection is in process. When your device is connected to the Home Tablet, you can manage your home tablet from anywhere.

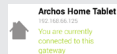



Connecting via a 3G network/an other WiFi network

- 1 Select the option **"If you are on a remote connection"**.



A code is requested to connect to the Home Tablet.

- 2 In the Home Tablet, launch the Archos Home app and select the Connection tab.



- 3 In the Connection tab, select **Authorize a device** in the Menu bar.



A 32-digits key is provided. It must be entered on the device that attempts to connect to the Home Tablet.

- 4 Type in the 32-digits key as the requested code.

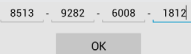

The connection is in process. When your device is connected to the Home Tablet, you can manage your home tablet from a distance.

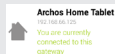



Programs





When your accessories are paired to your Home Tablet, you can create programs. A program is an action started by a trigger and scheduled at a period of time.

A Program interface

- ① Name of the program
- ② A trigger is an event that creates a sequence of actions
- ③ A duration sets the time-limit of an action
- ④ An action is the result of a triggering event
- ⑤ A schedule sets the period of validity for the sequence of actions
- ⑥ Save to validate the program and Cancel to stop the creation.

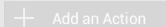

To create a program

- 1 Launch the Archos Home app .
 - 2 In the Archos Home app, select the Programs tab .
 - 3 Select  in the Menu bar.
- A window is displayed to create a program
- 4 Type in a name.
 - 5  : it can be a schedule, a detection, a weather event.
 - 6  : it can be a notification, a snapshot, a video. You can set a duration for the action
 - 7 Define a period of time when the event occurs.
 - 8 Select **SAVE**.

The program is created and is active.

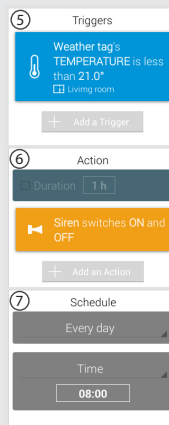

5 Triggers

Weather tag's TEMPERATURE is less than 21.0*
 Living room

+ Add a Trigger

6 Action

Duration 1 h

Siren switches ON and OFF

+ Add an Action

7 Schedule

Every day

Time 08:00

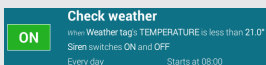



ON Check weather

when Weather tag's TEMPERATURE is less than 21.0*
Siren switches ON and OFF
Every day Starts at 08:00



Programs

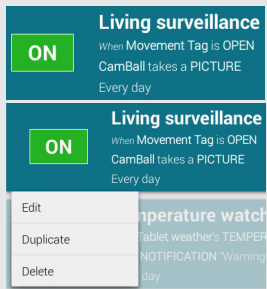

To modify a program

- 1 Launch the Archos Home app .
- 2 In the Archos Home app, select the Programs tab .
- 3 Select the program to be modified.
Options are displayed for the program.
- 4 Select Edit.
- 5 Make the modifications needed.
- 6 Select **SAVE**.



The screenshot shows two instances of the 'Living surveillance' program. The top instance has a green 'ON' button. Below it is a menu with options: 'Edit', 'Duplicate', and 'Delete'. The bottom instance also has a green 'ON' button. The text for both programs reads: 'Living surveillance', 'When Movement Tag is OPEN', 'CamBall takes a PICTURE', and 'Every day'. A third program, 'Temperature watch', is partially visible at the bottom.

To turn ON/OFF a program

- 1 Launch the Archos Home app .
 - 2 In the Archos Home app, select the Programs tab .
 - 3 Select the program to be turned on.
 - 4 Press **ON** to turn off the program **OFF**.
- Press **OFF** to turn it on back **ON**.



Archos Home Interactions

Your accessories are paired with your Home Tablet. The data from each accessory is displayed on the tablet.

Programs created on your tablet create interactions between the tablet and the accessories. In the Rooms tab, each square of information corresponds to a specific accessory.

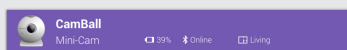

Tap a square of information to display history data.



Your phone helps manage your tablet and the accessories from a distance through the application Archos Home.





The Android™ Interface

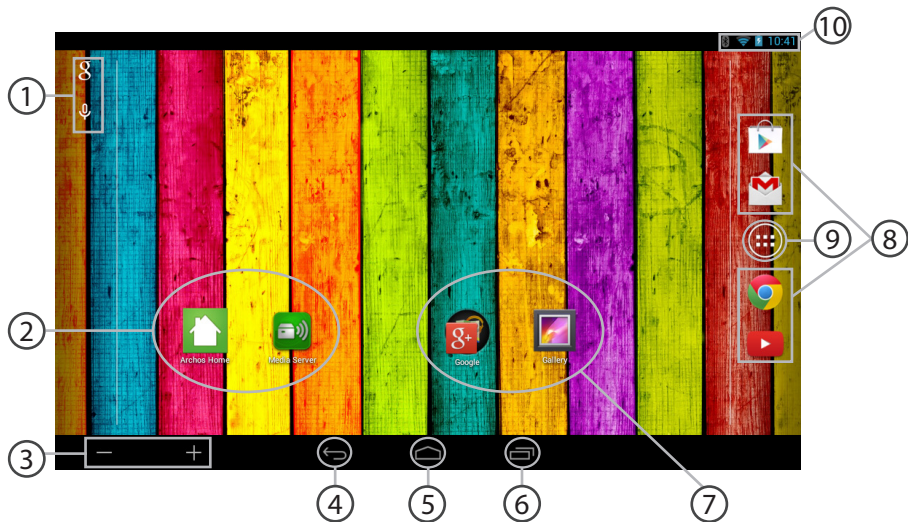



-
- ① **Google™ Search**
> Touch “Google” for text search or touch the microphone icon for voice search.
 - ② **ARCHOS apps**
 - ③ **Volume buttons**
 - ④ **Back button**
 - ⑤ **Home button**
 - ⑥ **Recent apps buttons**
 - ⑦ **Google apps shortcuts**
> Touch to start an application.
 - ⑧ **Permanent Android™ apps shortcuts**
> Touch to start an application
 - ⑨ **All Apps button**
> Touch this icon to show all the applications and widgets installed on your ARCHOS. All your downloaded applications are here.
 - ⑩ **The status bar**
> Displays notifications and quick settings



The Android™ Interface

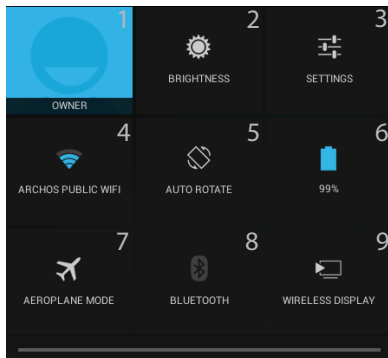

The Quick settings

- 1 Current user⁽¹⁾
- 2 To adjust the screen brightness.
- 3 To access all your settings.
- 4 To turn on/off your WiFi connection.
- 5 To activate/deactivate automatic screen orientation as you turn your ARCHOS.
- 6 Percentage of battery remaining
- 7 To activate/deactivate all wireless connections, especially when flying.
- 8 To display Bluetooth section
- 9 To enable wireless display⁽²⁾

⁽¹⁾New multi-user support for tablets lets different users have their own separate, customizable spaces on a single device. Add users in Settings > Device.

⁽²⁾You can share movies, YouTube videos, and anything that's on your screen on an HDTV. You need to connect a wireless display adapter to any HDMI-enabled TV to mirror what's on your screen quickly and easily.



The Recent Apps

Opens a list of thumbnail images of apps you've worked with recently:

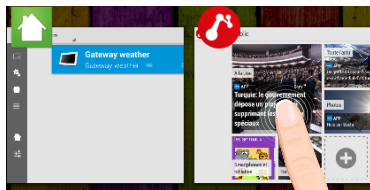

Touch: to open an app.

Hold down: to display options

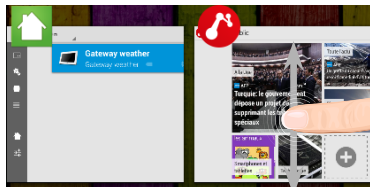

Swipe up or down: to close an app.



Getting familiar with Android™



The extended home screen:

Navigate between different home screen panels by swiping left and right.

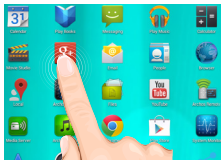

Moving a home screen item:

Touch and hold your finger onto it until the positioning gridlines appear, then slide it to the desired location, and release your finger.

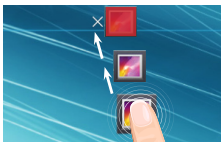

Removing a home screen item:

Touch and hold it, slide your finger towards the top of the screen and drop it over the Remove icon.



Uninstalling an item:

From the All apps screens, touch and hold it, slide your finger towards the top of the screen and drop it over Uninstall bin.



Creating application folders:

Drop one app icon over another on a home screen and the two icons will be combined.



Widgets:

Touch the All Apps icon on your home screen. Touch Widgets at the top of the screen. From the main Widgets screen, you can move around widgets just as you do for app icons.

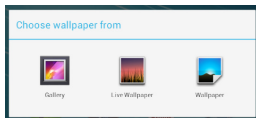

Changing your wallpaper:

Hold your finger on a home screen at an empty location, then choose from the list.

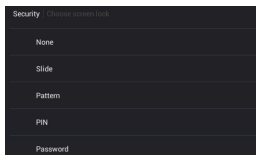

Locking the touchscreen:

In Settings, scroll down and touch security. Touch Screen lock. Touch the type of lock you would like to use. After you set a lock, a lock screen is displayed whenever your screen wakes up, requesting the pattern, PIN or other specified key.



Troubleshooting

What can i do in case of Bluetooth malfunctioning?

Go to Settings > Wireless & networks and select Bluetooth. Select Click to restart Bluetooth.

Bluetooth
Click to restart Bluetooth

Why i can't connect to my Home Tablet with my mobile device?

You may be connected to a protected network using firewalls. In that case, you are prevented from connecting to your Home Tablet.

Why aren't my accessories responding?

Are they correctly paired to your Home Tablet?

Check if Bluetooth is ON in the tablet.

Check if the batteries are not empty. In that case, you need to change them.

How can i restore my device to its default settings?

1. When the device is turned off, plug the power cable into the power connector.
2. As soon as the ARCHOS bootlogo is displayed, press the reset button for 5 seconds with the end of a paper clip.

The Android recovery interface is displayed.

3. Select an option with your finger.
4. Validate with the ON/OFF Button.

- Select "Wipe data/factory reset" and validate to restore your device to its default settings.
- Select "Yes -- delete all user data" and validate to remove all the user data.
- Select "Reboot system now" and validate to reboot the device.

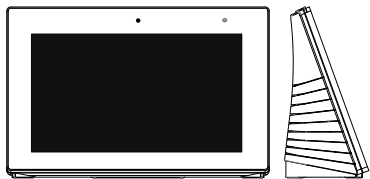

Table des matières

Contenu de la boîte.....	38
Mise en route.....	39
ARCHOS Mini-Cam.....	40
ARCHOS Weather Tag.....	42
ARCHOS Movement Tag.....	44
Description du ARCHOS Smart Home Tablet.....	46
Assistant de démarrage.....	47
Se connecter à un réseau WiFi.....	48
L'interface ARCHOS Home.....	50
ARCHOS Home - Premiers Pas.....	52
L'interface des Accessoires.....	56
Gérer les Accessoires.....	57
Se connecter à la Home Tablet.....	60
Programmes.....	62
Interactions avec l'ARCHOS Home.....	65
L'interface Android TM	66
Se familiariser avec Android TM	70
Dépannage.....	72
Pour plus d'informations, consultez-les FAQs sur www.archos.com . Consultez-les avant d'envisager un éventuel retour du produit.	



Contenu de la boîte



ARCHOS Smart Home Tablet



Mini Cam
X 2



Weather Tag
X 2



Movement Tag
X 2



Câble USB

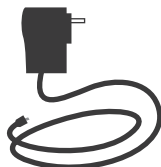

Chargeur



Guide d'utilisation
rapide



Guide des garanties et
des mentions légales



Mise en route

FR

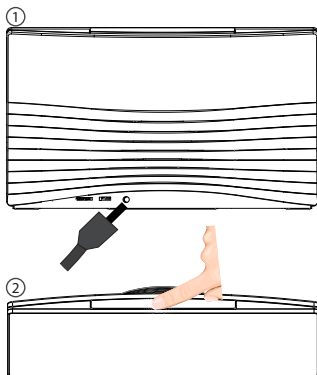

1. Connectez le câble d'alimentation à votre produit via le connecteur d'alimentation. Le témoin de charge est bleu lorsque le câble d'alimentation est branché. L'appareil commence à se charger.
2. Appuyez sur le bouton ON/OFF pour allumer la tablette.
 - Vous pouvez utiliser votre tablette pendant le chargement.
 - Lors de la première utilisation, chargez complètement la batterie.
 - Utilisez uniquement le chargeur fourni.



! Votre tablette doit rester connectée à son câble d'alimentation.

ASTUCES:

Pour bénéficier d'une assistance complète, enregistrez votre produit. A partir de votre ordinateur, allez sur www.archos.com/register.



ARCHOS Mini-Cam

Description de la Mini Cam

- ① Bouton d'association
- ② Témoin de fonctionnement
- ③ Objectif de la caméra
- ④ Micro
- ⑤ Sticker

Mise en service de la Mini Cam

Votre caméra fonctionne avec 3 piles Lithium cell CR 24 50.

1. Dévissez la caméra.
2. Enlevez l'étiquette isolante "remove before use".
3. Revissez la caméra.
4. Placez la caméra sur son support.
Des aimants maintiennent la caméra. Vous pouvez orienter la caméra vers n'importe quelle direction.
5. Enlevez le sticker apposé sur le support afin de fixer la caméra sur un mur ou un plafond.

un appui long sur le bouton d'association pendant 5 secondes	le témoin clignote pendant 60 secondes	La caméra est en mode association et tente de se connecter à la tablette.
un appui court sur le bouton d'association	le témoin clignote pendant 10 secondes	La caméra est déjà associée à la tablette mais est déconnectée. Elle tente de se reconnecter.
	le témoin clignote 3 fois	La caméra est dissociée et déconnectée.
	le témoin est allumé pendant 5 secondes	La caméra est associée et connectée.
	le témoin clignote rapidement	Une mise à jour via WiFi est en cours.

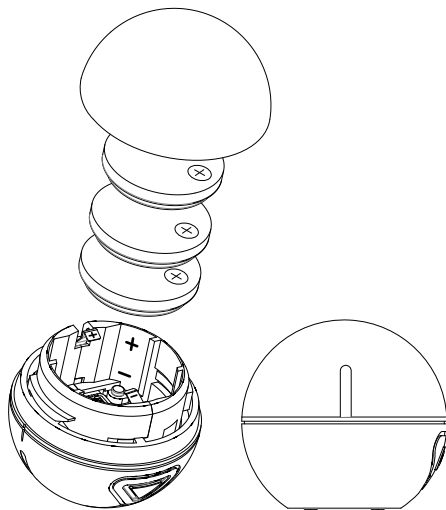
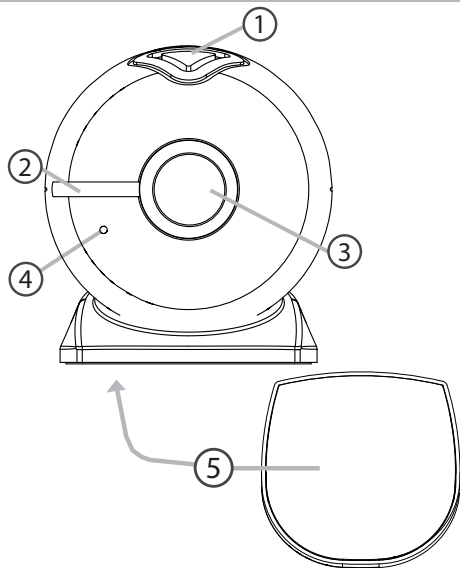



ARCHOS Weather Tag

Description de la Weather Tag

- ① Bouton d'association
- ② Témoin de fonctionnement
- ③ Ouverture
- ④ Sticker

Mise en service de la Weather Tag

Votre Weather Tag fonctionne avec une pile Lithium cell CR 24 30.

1. Enlevez l'enveloppe en caoutchouc.
2. Séparez le haut du boîtier du bas.
3. Enlevez l'étiquette isolante "remove before use".
4. Remettez en place le boîtier en place et l'enveloppe.
5. Enlevez le sticker apposé sur le dos du boîtier pour fixer l'appareil sur un mur.

un appui long sur le bouton d'association pendant 5 secondes	le témoin clignote pendant 60 secondes	La caméra est en mode association et tente de se connecter à la tablette.
un appui court sur le bouton d'association	le témoin clignote pendant 10 secondes	La caméra est déjà associée à la tablette mais est déconnectée. Elle tente de se reconnecter.
	le témoin clignote 3 fois	La caméra est dissociée et déconnectée.
	le témoin est allumé pendant 5 secondes	La caméra est associée et connectée.
	le témoin clignote rapidement	Une mise à jour via WiFi est en cours.

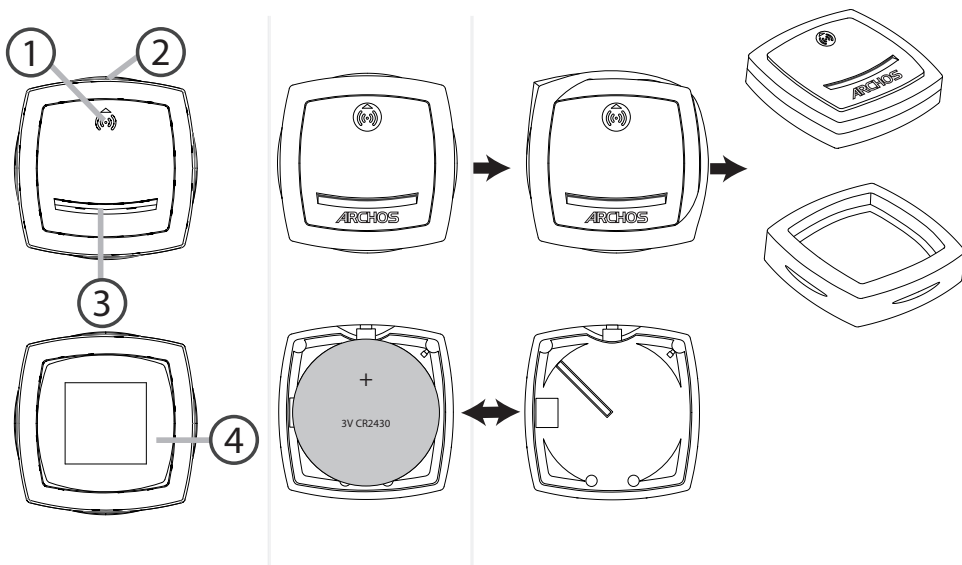



ARCHOS Movement Tag

Description du Movement Tag

- ① Aimant
- ② Détecteur d'aimant
- ③ Indicateur du détecteur d'aimant
- ④ Bouton d'association
- ⑤ Témoin d'association
- ⑥ Enveloppe en caoutchouc

Mise en service du Movement Tag

Votre Movement Tag fonctionne avec une pile Lithium cell CR 24 30.

1. Enlevez l'enveloppe en caoutchouc de l'appareil.
2. Séparez le haut du boîtier du bas.
3. Enlevez l'étiquette isolante "remove before use".
4. Remettez en place le boîtier et l'enveloppe.
5. Enlevez le sticker apposé sur le dos du boîtier pour fixer l'appareil sur un mur.
6. Enlevez le sticker apposé sur l'aimant pour le positionner en face de l'indicateur du détecteur d'aimant.

un appui long sur le bouton d'association pendant 5 secondes	le témoin clignote pendant 60 secondes	La caméra est en mode association et tente de se connecter à la tablette.
un appui court sur le bouton d'association	le témoin clignote pendant 10 secondes	La caméra est déjà associée à la tablette mais est déconnectée. Elle tente de se reconnecter.
	le témoin clignote 3 fois	La caméra est dissociée et déconnectée.
	le témoin est allumé pendant 5 secondes	La caméra est associée et connectée.
	le témoin clignote rapidement	Une mise à jour via WiFi est en cours.



FR

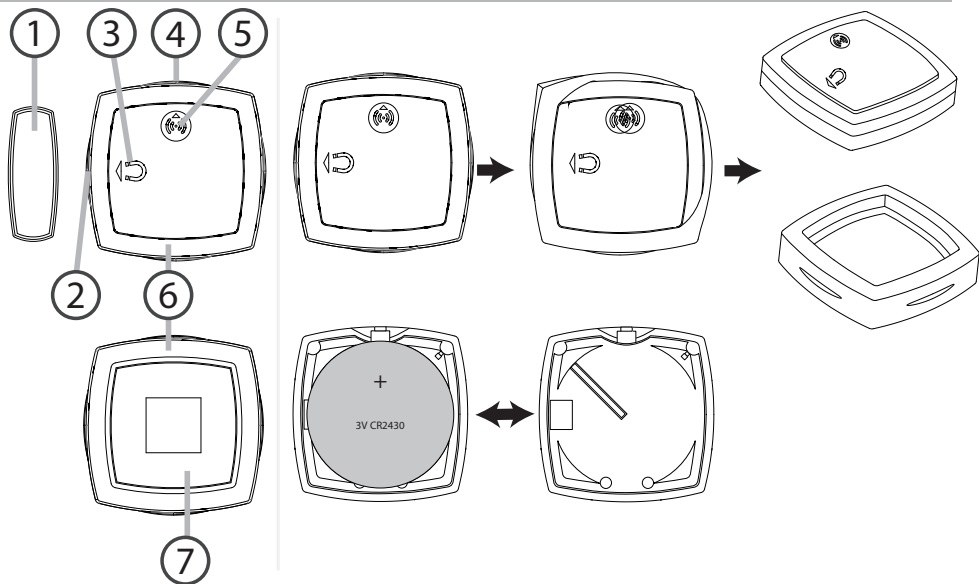



Description de l'appareil

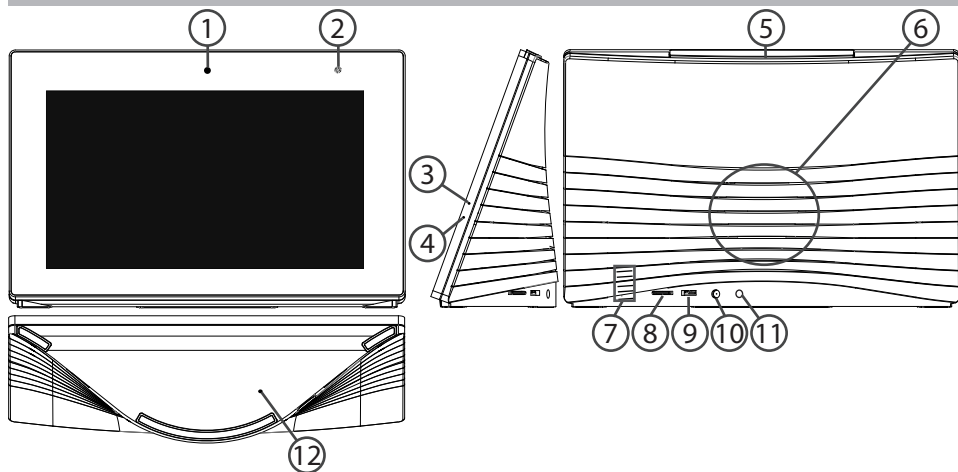

- | | | | |
|---------------------------|-----------------|--------------------------|-----------------------------|
| ① Webcam | ④ Micro | ⑦ Thermomètre intégré | ⑩ Connecteur d'alimentation |
| ② Détecteur de luminosité | ⑤ Bouton ON/OFF | ⑧ Lecteur carte micro-SD | ⑪ Entrée jack audio |
| ③ Témoin de charge | ⑥ Haut-parleur | ⑨ Port micro-USB | ⑫ Bouton Reset |



L'assistant de démarrage

FR

La première fois que vous allumez votre tablette, l'assistant de démarrage vous permet de paramétrer votre appareil :

- Langue
- Connexion WiFi
- Paramétrage d'un compte Google
- Les options du service de localisation
- Applications tierces

ASTUCES :

Pour le paramétrage de votre appareil, nous vous recommandons de vous placer dans la zone WiFi du réseau que vous utilisez régulièrement.



Se connecter à un réseau WiFi

ATTENTION : assurez-vous d'être dans une zone WiFi.



① Sélectionnez les icônes Heure et Batterie en maintenant votre doigt appuyé afin d'afficher la barre de statuts.



② Tirez vers le bas la barre bleue pour afficher le panneau des statuts.



③ Sélectionnez "WiFi éteint" dans le panneau des statuts. L'écran "WiFi" s'affiche.



④ Si le WiFi est éteint, faites-glisser l'interrupteur WiFi sur la position "OUI".

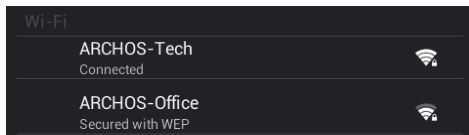

⑤ Une fois que le WiFi est activé, la tablette recherche des réseaux WiFi à portée. Sélectionnez le nom du réseau auquel vous voulez vous connecter.

Les réseaux privés sont affichés avec un cadenas. Ils nécessitent un mot de passe.



Connexion rapide

Vous pouvez vous connecter à votre réseau WiFi via le service WPS (WiFi Protected Setup).

Press the WiFi Protected Setup button on your router. It may be called "WPS" or contain this symbol:

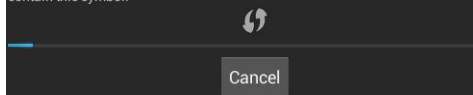

① Appuyez sur le bouton WPS  dans Paramètres > Sans fil et réseaux.

② Sur votre routeur Internet, appuyez le bouton WPS nommé WPS ou qui porte le symbole .

ASTUCES :

- Lorsque vous saisissez un mot de passe, nous vous recommandons de cocher «Afficher mot de passe» afin de voir les caractères que vous saisissez. Pour obtenir le mot de passe ou les paramètres du réseau WiFi, contactez le fournisseur d'accès à Internet. Si votre WiFi est activé et que vous êtes à portée d'un réseau auquel vous vous êtes déjà connecté, votre tablette tente d'établir automatiquement une connexion.
- Pour maintenir votre connexion WiFi active lorsque la tablette est en veille, sélectionnez l'icône de Menu dans l'écran "WiFi", puis sélectionnez Options avancées > WiFi actif en veille > Toujours.

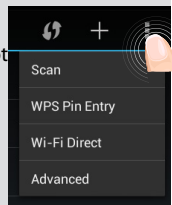



L'interface ARCHOS HOME

The screenshot displays the ARCHOS HOME interface. At the top left, a hand icon points to a row of colorful application icons. Below this is a 'Rooms' header with a house icon and a window icon (8). A navigation bar below 'Rooms' shows 'KITCHEN' and 'LIVING' (7). A vertical sidebar on the left contains icons for: 1. Window management, 2. Settings, 3. Home indicator, 4. Menu, 5. Mobile device, and 6. Network/Bluetooth. The main content area shows a 'Weather' widget (22.7° TEMPERATURE, 46% HUMIDITY) and a 'Movement Tag' widget (Idle UNKNOWN). A 'Closed' widget (UNKNOWN) is also visible. A '11:59' timestamp is shown in the bottom left of the video feed.



- ① **Onglet Pièces :**
affiche les pièces créées et qui correspondent aux pièces de votre maison.
- ② **Onglet Programmes :**
affiche les programmes créés en rapport avec les accessoires associés.
- ③ **Onglet Tous les accessoires :**
affiche tous les accessoires associés avec l'Archos Smart Home Tablet.
- ④ **Onglet Historique :**
affiche l'historique des actions des différents accessoires.
- ⑤ **Onglet Connexion :**
permet de connecter des appareils utilisés pour commander la tablette à distance.
- ⑥ **Onglet Général :**
permet d'ajouter des notifications et de gérer les paramètres.
- ⑦ **Pièce affichée :**
affiche les accessoires placés dans la pièce. Glissez l'écran vers la gauche ou la droite pour afficher les autres pièces.
- ⑧ **Barre de menus :**
affiche des boutons de menu correspondant à l'onglet affiché.



ARCHOS HOME - Premiers Pas

La première fois que vous lancez l'application, vous devrez créer des pièces. Les pièces créées doivent correspondre aux pièces où vous installez les accessoires.

PIECES

Pour créer une pièce

1 Lancez l'application Archos Home.

2 Sélectionnez Ajouter une pièce.

3 Nommez la pièce et sélectionnez OK.

Vous pouvez créer autant de pièces que vous voulez.

4 A la fin, sélectionnez Terminé.



Rooms



+ Add a room

Done



ASSOCIATION

Après la création de pièces, l'étape suivante vous permet d'associer des accessoires avec votre tablette.

Pour associer un accessoire

1 Vérifiez que le Bluetooth est activé sur la tablette. Dans le cas contraire, redémarrez le à partir de Paramètres > Sans fil et réseaux.

2 Sélectionnez l'accessoire souhaité.

Assurez-vous d'avoir enlevé l'étiquette "remove before use" insérée entre les piles.

3 Appuyez sur le bouton d'association de l'accessoire pendant 5 secondes.

Le témoin d'association clignote.

4 Appuyez sur le bouton Démarrer sur la tablette.

L'association débute.

Si l'association réussit, le message suivant s'affiche: **Association réussie!**
Appuyez sur OK pour continuer.

Successfully paired!
Press OK to continue

5 Sélectionnez OK.

Vous avez le choix de relier l'accessoire avec une pièce existante.



ARCHOS HOME - Premiers Pas

Si l'association échoue, le message suivant s'affiche :

Timeout
Press Cancel to continue

Est-ce que le Bluetooth est activé?

- 1 Sélectionnez l'application Paramètres sur la tablette.
- 2 Dans la section Sans fil & réseaux, redémarrez le Bluetooth.

Est-ce que le témoin d'association de l'accessoire clignote?

Pour le faire clignoter, appuyez sur le bouton d'association pendant 5 secondes.

Recommencez le processus d'association.

ASTUCES:

Un appui long sur le bouton d'association pendant 5 secondes :

Le témoin clignote pendant 60 secondes. La caméra est en mode association et tente de se connecter à la tablette.

Un appui court sur le bouton d'association :

Le témoin clignote pendant 10 secondes. La caméra est déjà associée à la tablette mais est déconnectée. Elle tente de se reconnecter.

Le témoin est allumé pendant 5 secondes. La caméra est associée et connectée.

Le témoin clignote rapidement. Une mise à jour via WiFi est en cours.



NOMMER

Après l'association, vous devez nommer l'accessoire.

Pour nommer un accessoire

1 Entrez un nom pour l'accessoire.

Choisissez un nom qui vous permet d'identifier facilement l'accessoire ainsi que sa position.

2 Sélectionnez OK.

RELIER

Après avoir nommé l'accessoire, sélectionnez la pièce avec laquelle vous souhaitez la relier.

Pour relier un accessoire à une pièce

1 Sélectionnez la pièce ou les pièces choisies.

2 Sélectionnez Terminé.

A la fin du paramétrage, vos accessoires s'affichent dans l'onglet Tous les accessoires.



Interface des accessoires

Onglet Tous les accessoires

All accessories Sort by room Bluetooth +

① Living ② ③ ④

CamBall
Mini-Cam 39% Online Living ⑤

Movement Tag
Movement Tag 90% Online Living

Weather
Weather Tag 92% Online Living

①	Nom de la section
②	Type de tri
③	Qualité de la connexion Bluetooth
④	Ajouter plus d'accessoires
⑤	<ul style="list-style-type: none">- Niveau de batterie- Statut de la connexion- Pièce dans laquelle l'accessoire est



Gérer les accessoires

FR



Comment créer plus de pièces?

- 1 Dans l'application Archos Home, sélectionnez l'onglet Pièces .
- 2 Dans l'onglet Pièces, sélectionnez l'icône Pièces dans la barre de menus.
- 3 Sélectionnez Ajouter une pièce et nommez la pièce. Sélectionnez Terminé à la fin.

Rooms





Comment modifier une pièce déjà créée?

- 1 Dans l'application Archos Home, sélectionnez l'onglet Pièces.
- 2 Dans l'onglet Pièces, sélectionnez l'icône  dans la barre de menus.
- 3 A côté du nom de chaque pièce, sélectionnez  pour modifier ou supprimer la pièce.
- 4 Sélectionnez Terminé à la fin.



Gérer les accessoires

Comment ajouter plus d'accessoires?

- 1 Dans l'application Archos Home, sélectionnez l'onglet Tous les accessoires .
- 2 Dans l'onglet Tous les accessoires, sélectionnez l'icône  dans la barre des menus.
- 3 Sélectionnez le type d'accessoire à associer avec la tablette.

Assurez-vous d'avoir enlevé l'étiquette "remove before use" insérée entre les piles.

- 4 Appuyez sur le bouton d'association de l'accessoire pendant 5 secondes.

Le témoin d'association clignote.

- 5 Appuyez sur le bouton Démarrer de la tablette.

L'association démarre.

Sélectionnez OK si l'association réussit. En cas d'échec, recommencez le processus. Voir les sections précédentes sur les accessoires.

All accessories 



Accessories

Click on the accessory type you want to pair





Comment renommer un accessoire?



- 1 Dans l'application Archos Home, sélectionnez l'onglet Tous les accessoires .
- 2 Dans l'onglet Tous les accessoires, sélectionnez l'accessoire à renommer .

Une liste d'options s'affiche.

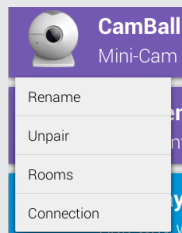
- 3 Sélectionnez Renommer, puis OK.



Comment relier un accessoire à une pièce?

- 1 Dans l'application Archos Home, sélectionnez l'onglet Tous les accessoires .
- 2 Dans l'onglet Tous les accessoires, sélectionnez l'accessoire  à renommer.

Une liste d'options s'affiche.

- 3 Sélectionnez "Pièces".

- 4 Sélectionnez la pièce ou les pièces souhaitées, puis OK.

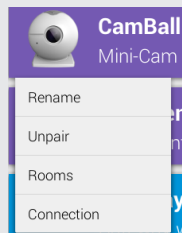



Se Connecter avec son Appareil Mobile

Vous pouvez gérer l'Archos Smart Home Tablet à distance avec un téléphone ou une tablette.

Télécharger l'application

- 1 Télécharger l'application à partir du Play Store ou de l'Appstore ou bien utilisez le Flash code sur la boîte.
- 2 Après le téléchargement, lancez l'application.

La première fois que vous lancez l'application, vous avez deux options pour vous connecter à l'Archos Smart Home Tablet.

Se connecter à partir du même réseau WiFi

- 1 Sélectionnez l'option "**Si vous êtes sur le même réseau WiFi que l'ARCHOS Smart Home Tablet**".



Le message suivant s'affiche : "**Recherche du ARCHOS Smart Home Tablet sur votre réseau**".

- 2 Appuyez sur Se connecter.



Une autorisation de connexion est envoyée à la tablette.

- 3 Sélectionnez **Autoriser** sur la tablette pour permettre à l'appareil de se connecter à la tablette.



La connexion tente d'être établie. Lorsque votre appareil est connecté à la tablette, vous pouvez gérer votre tablette à distance.

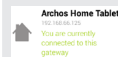



Se connecter via la 3G/à partir d'un réseau WiFi différent

- 1 Sélectionnez l'option "**A partir d'un réseau WiFi différent**".



Un code est nécessaire pour se connecter à la tablette.

- 2 A partir de la tablette, lancez l'application Archos Home et sélectionnez l'onglet Connexion.



- 3 Dans l'onglet Connexion, sélectionnez **Autoriser un appareil** à partir de la barre de menus.

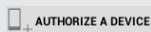

Une clé à 32 chiffres est fournie.

- 4 Saisissez la clé de 32 chiffres sur votre appareil mobile.

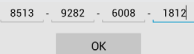

La connexion tente d'être établie. Lorsque votre appareil est connecté à la tablette, vous pouvez gérer votre tablette à distance.

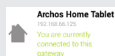



Programmes





Lorsque vos accessoires sont associés à votre tablette, il est possible de créer des programmes. Un programme est une action qui commence grâce à un élément déclencheur et qui a une durée dans le temps.

L'interface d'un programme

- ① Nom du programme
- ② Un élément déclencheur est un événement qui cause une succession d'actions
- ③ Définir une durée permet de déterminer l'occurrence d'une action
- ④ Une action est le résultat d'un événement déclencheur
- ⑤ Définir un calendrier permet de déterminer le moment au cours duquel la succession d'actions doit être prise en compte
- ⑥ Enregistrer pour valider le programme et Annuler pour stopper la création.

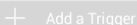

Pour créer un programme

- 1 Lancez l'application Archos Home .
 - 2 Dans l'application Archos Home, sélectionnez l'onglet Programmes .
 - 3 Sélectionnez  dans la barre de menus.
- A window is displayed to create a program
- 4 Saisissez un nom.
 - 5  : l'élément déclencheur peut être une date, une détection ou un événement météorologique.
 - 6  : l'action peut être une notification, une photo, une vidéo. Vous pouvez fixer la durée de l'action.
 - 7 Définissez un calendrier au cours duquel l'événement a lieu.
 - 8 Sélectionnez **Enregistrer**.

Le programme est créé et est en marche.

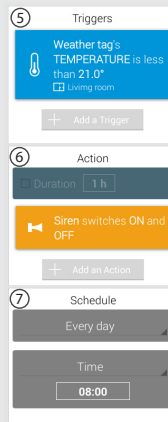

5 Triggers

Weather tag's TEMPERATURE is less than 21.0°
 Living room

+ Add a Trigger

6 Action

Duration 1 h

Siren switches ON and OFF

+ Add an Action

7 Schedule

Every day

Time 08:00

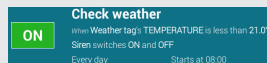



Check weather

ON When Weather tag's TEMPERATURE is less than 21.0°
Siren switches ON and OFF
Every day Starts at 08:00



Programmes

Pour modifier un programme

- 1 Lancez l'application Archos Home .
 - 2 Dans l'application Archos Home, sélectionnez l'onglet Programmes .
 - 3 Sélectionnez le programme à modifier.
- Des options s'affichent pour le programme.
- 4 Sélectionnez Modifier.
 - 5 Faites les modifications nécessaires.
 - 6 Sélectionnez **Enregistrer**.

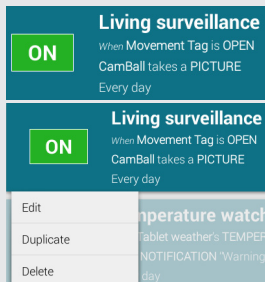

Living surveillance
When Movement Tag is OPEN
CamBall takes a PICTURE
Every day

ON



Living surveillance
When Movement Tag is OPEN
CamBall takes a PICTURE
Every day

ON

Edit
Duplicate
Delete

temperature watch
Tablet weather's TEMPER
NOTIFICATION Warning
day

Pour activer/désactiver un programme

- 1 Lancez l'application Archos Home .
 - 2 Dans l'application Archos Home, sélectionnez l'onglet Programmes .
 - 3 Sélectionnez le programme à activer.
 - 4 Appuyez sur **ON** pour désactiver le programme **OFF**.
- 64 Press **OFF** to turn it on back **ON**.



Interactions dans l'Archos Home

FR

Vos accessoires sont associées avec votre tablette. Les données transmises par chaque accessoire sont affichées sur la tablette.



Des programmes créés sur votre tablette amènent des interactions entre la tablette et les accessoires. Dans l'onglet Pièces, chaque bloc d'informations correspond à un accessoire spécifique.



Appuyez sur un bloc d'informations pour afficher l'historique des données.

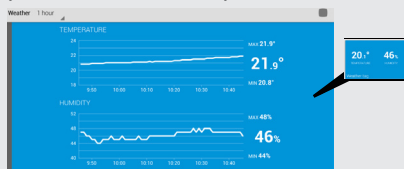

Votre appareil mobile permet de gérer votre tablette ainsi que les accessoires tout en étant à distance grâce à l'application Archos Home.





L'interface Android™

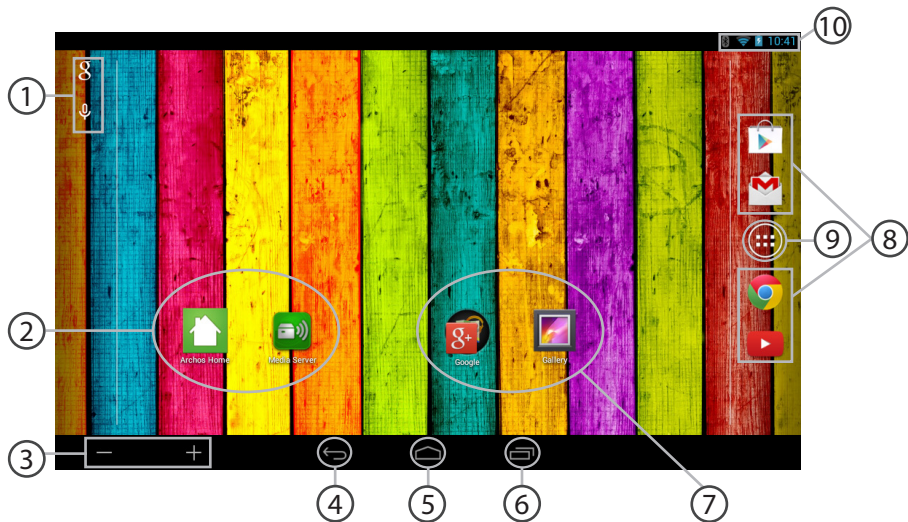



- ① **Google™ Search**
> Sélectionnez “Google” pour saisir votre recherche ou l’icône microphone pour l’énoncer.
- ② **Applications ARCHOS**
- ③ **Boutons de volume**
- ④ **“Retour”**
- ⑤ **“Accueil”**
- ⑥ **“Applications récentes”**
- ⑦ **Raccourcis d’applications Google**
> Sélectionnez une application pour l’ouvrir.
- ⑧ **Raccourcis permanents d’applications Android**
- ⑨ **“Toutes les Applications”**
> Sélectionnez pour afficher toutes les applications et les widgets installés sur votre ARCHOS. Vous retrouverez toutes vos applications téléchargées.
- ⑩ **Barre de statuts**
> Elle affiche les notifications et permet l’accès aux réglages rapides.



L'interface Android™

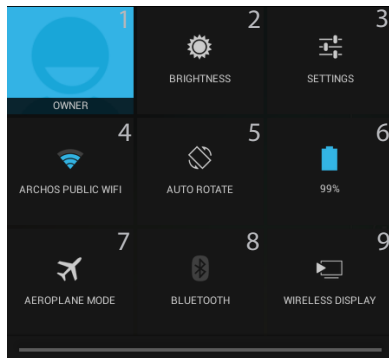

3:18 Les Réglages rapides

- 1 Affiche l'icône de l'utilisateur actuel⁽¹⁾.
- 2 Pour ajuster la luminosité de l'écran.
- 3 Pour accéder à tous vos paramètres.
- 4 Pour activer/désactiver votre connexion WiFi.
- 5 Pour activer/désactiver l'orientation automatique de l'écran dès que vous tournez votre tablette.
- 6 Pourcentage de batterie restant
- 7 Pour activer/désactiver toutes les connexions sans fil. Par exemple, pour prendre l'avion.
- 8 Pour afficher la section Bluetooth
- 9 Pour permettre l'affichage sans fil⁽²⁾

⁽¹⁾Cette option permet à différents utilisateurs d'une même tablette d'avoir chacun son propre espace personnalisable. Ajoutez des utilisateurs à partir de Paramètres > Appareil.

⁽²⁾Vous pouvez partager sur votre téléviseur HD des films, des vidéos de YouTube et tout autre média affiché sur votre tablette. Il faut au préalable connecter un adaptateur Wi-Di au port HDMI de votre téléviseur pour dupliquer facilement et rapidement ce qui est affiché sur votre tablette.



Les Applications récentes

L'application affiche une liste de vignettes des applications utilisées récemment.

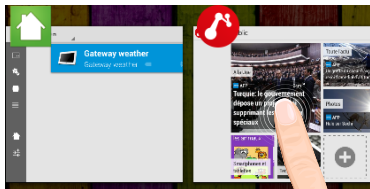

Pour afficher une application, sélectionnez-la.

Pour afficher des informations, maintenez appuyé.

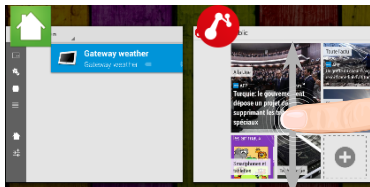

Pour fermer une application, faites-la glisser vers le haut ou vers le bas.



Se familiariser avec Android™



L'écran d'accueil étendu :

Naviguez entre les différents écrans d'accueil en faisant glisser votre doigt vers la gauche ou vers la droite.



Déplacer une icône de l'écran d'accueil :

Maintenez votre doigt appuyé sur l'icône jusqu'à ce que s'affichent les lignes de positionnement, puis faites-la glisser vers l'emplacement souhaité, et relâchez.

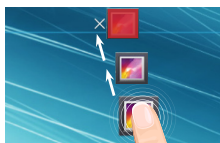

Supprimer une icône de l'écran d'accueil :

Maintenez votre doigt appuyé sur l'icône, puis faites-la glisser vers le haut de l'écran, et déposez-la sur l'icône "Supprimer".



Désinstaller une application :

A partir de l'écran "Toutes les applications", maintenez votre doigt appuyé sur l'icône, puis faites-la glisser vers le haut de l'écran et déposez-la sur l'icône "Désinstaller".



Créer des dossiers d'applications :

A partir d'un écran d'accueil, déposez une icône sur une autre pour les rassembler.



Widgets :

Sélectionnez l'icône "Toutes les applications". Sélectionnez "Widgets" en haut de l'écran. A partir de l'écran d'accueil des widgets, vous pouvez déplacer les widgets de la même façon que vous procédez avec les applications.

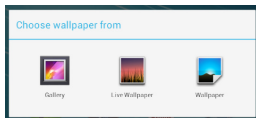

Changer le fond d'écran :

Maintenez votre doigt appuyé sur un emplacement vide de l'écran, puis choisissez parmi la liste d'options.

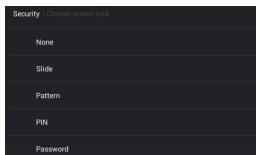

Verrouiller votre tablette :

A partir du panneau des réglages rapides dans la barre de statut, sélectionnez "Paramètres". Faites défiler l'écran vers le bas, puis sélectionnez "Sécurité". Sélectionnez "Verrouillage de l'écran". Sélectionnez le type de verrouillage que vous voulez utiliser. Une fois que vous avez sélectionné une option, un écran de verrouillage s'affiche chaque fois que votre écran est réactivé. Vous êtes alors invité à saisir le schéma, le code PIN ou tout autre code spécifié.



Dépannage

Que puis-je faire en cas de dysfonctionnement du Bluetooth?

Allez dans Paramètres > Sans fil et réseaux et sélectionnez Bluetooth.

Sélectionnez Cliquez pour redémarrer le Bluetooth.

Pourquoi je ne peux pas me connecter à ma tablette avec mon appareil mobile?

Il se peut que vous soyez connectés à un réseau protégé utilisant des pare-feux. Si c'est le cas, vous ne pourrez vous connecter à votre tablette.

Pourquoi les accessoires n'interagissent plus avec la tablette?

Sont-ils correctement associés à votre tablette?

Vérifiez que le Bluetooth est activé sur la tablette.

Vérifiez que les piles ne sont pas à plat. Si c'est le cas, il faudra les changer.

Comment restaurer ma tablette aux valeurs d'usine?

1. Lorsque l'appareil est éteint, connectez le câble d'alimentation au connecteur d'alimentation.
2. Dès que le logo de démarrage ARCHOS s'affiche, appuyez sur le bouton Reset pendant 5 secondes avec un trombone.

L'interface Android recovery s'affiche.

3. Sélectionnez une option avec votre doigt.

4. Validez avec le bouton ON/OFF.

- Sélectionnez "Wipe data/factory reset" et validez pour restaurer votre appareil aux valeurs d'usine.
- Sélectionnez "Yes -- delete all user data" et validez pour supprimer toutes les données utilisateur.
- Sélectionnez "Reboot system now" et validez pour redémarrer l'appareil.



Inhaltsverzeichnis

Verpackungsinhalt.....	74
Erste Schritte.....	75
ARCHOS Mini-Cam.....	76
ARCHOS Weather Tag.....	78
ARCHOS Movement Tag.....	80
Beschreibung von ARCHOS Smart Home Tablet.....	82
Der Assistent.....	83
Verbindung zu einem WLAN-Netzwerk herstellen.....	84
Die ARCHOS Home-Benutzeroberfläche.....	86
ARCHOS Home - Erstmalige Einrichtung.....	88
Benutzeroberfläche Accessories [Zubehör].....	92
Verwaltung des Zubehörs.....	93
Verbindung zum Mobiltelefon.....	96
Programme.....	98
ARCHOS Home Interaktionen.....	101
Die Android™ Benutzeroberfläche.....	102
Erste Schritte mit Android™.....	106
Fehlerbehebung.....	108

Weitere Informationen finden Sie unter den FAQs unter www.archos.com. Bitte lesen Sie diese Informationen sorgfältig, bevor Sie die Rückgabe eines Produkts erwägen.



Beschreibung des Packungsinhalts

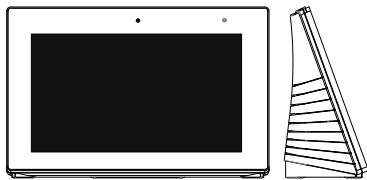

ARCHOS Smart Home Tablet



Mini Cam
X 2



Weather Tag
X 2



Movement Tag
X 2



USB Kabel



Ladegerät



Benutzerhandbuch



Garantie, Impressum
und Sicherheitshinweise



Erste Schritte

DE

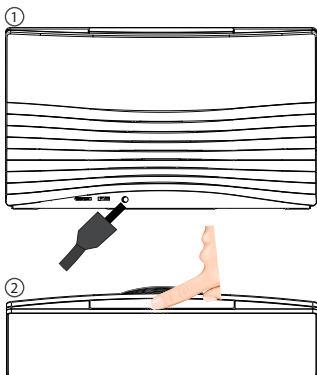

1. Verbinden Sie Ihr Netzkabel mit dem Stromanschluss. Bei eingestecktem Netzkabel leuchtet die Betriebsanzeige blau. Das Gerät wird jetzt geladen.
2. Drücken Sie die EIN/AUS-Taste, um das Gerät einzuschalten.
 - Während des Ladens können Sie Ihren ARCHOS wie gewohnt weiter verwenden.
 - Laden Sie Ihr Gerät vor der ersten Nutzung einmal vollständig auf.
 - Verwenden Sie nur das mitgelieferte Ladegerät.



Ihr Gerät sollte, wann immer möglich, mit dem Stromanschluss verbunden werden.

TIPP:

Um unseren Service voll nutzen zu können, empfehlen wir Ihnen, Ihr Produkt zu registrieren. Für die Registrierung mittels Computer gehen Sie zu www.archos.com/register.



ARCHOS Mini Cam

Beschreibung der Mini Cam

- 1 Paarungstaste
- 2 Paarungsanzeige
- 3 Kameraobjektiv
- 4 Mikrofon
- 5 Aufkleber

Installation der Mini Cam

Die Kamera wird mit 3 Lithiumzellen CR 2450 betrieben.

1. Den Kameraball abschrauben.
2. Den Isolationsaufkleber "Remove before use [Vor Verwendung entfernen]" entfernen.
3. Wieder festschrauben.
4. Die Kamera auf dem Fuß platzieren.
Stabilität wird hier durch Magneten erreicht. Die Kamera kann in jede Richtung bewegt werden.
5. Entfernen Sie den Aufkleber auf dem Fuß, um das Gerät an eine Wand oder Decke zu kleben.

Bei langem Drücken der Paarungstaste (5 Sekunden)	LED blinkt 60 Sekunden	Das Gerät befindet sich im Paarungsmodus und versucht, zu einem Tablet zu verbinden.
Kurzes Drücken der Paarungstaste	LED blinkt 10 Sekunden	Das Gerät wurde bereits gepaart, ist aber getrennt. Es versucht, zu verbinden.
	LED blinkt dreimal	Das Gerät wurde nicht gepaart und ist getrennt.
	LED LEUCHTET 5 Sekunden	Das Gerät wurde gepaart und ist verbunden.
	LED blinkt schnell	Ein Over-the-Air-Update wird ausgeführt.



DE

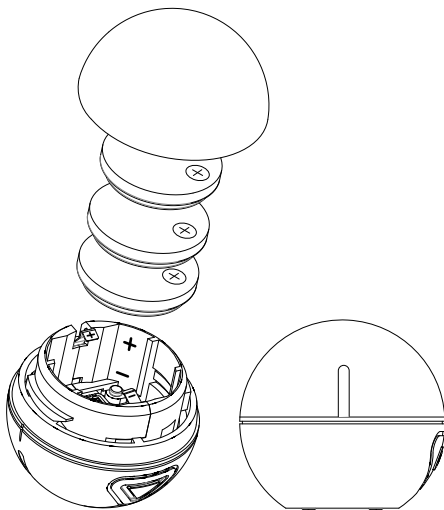
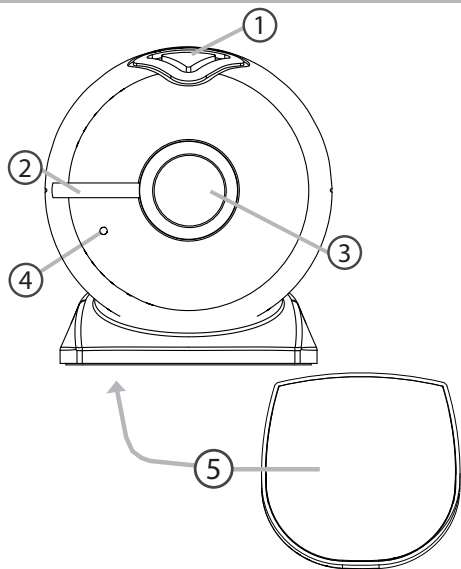



ARCHOS Weather Tag

Beschreibung von Weather Tag

- 1 Paarungsanzeige
- 2 Paarungstaste
- 3 Öffnen
- 4 Aufkleber

Installation von Weather Tag

Weather Tag wird mit einer Lithiumzelle CR 2430 betrieben.

1. Das Gummigehäuse entfernen.
2. Das Oberteil des hinteren Gehäuses abnehmen.
3. Den Isolationsaufkleber "Remove before use [Vor Verwendung entfernen]" entfernen.
4. Hinteres Gehäuse und Gummi wieder befestigen.
5. Entfernen Sie den Aufkleber auf dem hinteren Gehäuse, um das Gerät an eine Wand oder Decke zu kleben.

Bei langem Drücken der Paarungstaste (5 Sekunden)	LED blinkt 60 Sekunden	Das Gerät befindet sich im Paarungsmodus und versucht, zu einem Tablet zu verbinden.
Kurzes Drücken der Paarungstaste	LED blinkt 10 Sekunden	Das Gerät wurde bereits gepaart, ist aber getrennt. Es versucht, zu verbinden.
	LED blinkt dreimal	Das Gerät wurde nicht gepaart und ist getrennt.
	LED LEUCHTET 5 Sekunden	Das Gerät wurde gepaart und ist verbunden.
	LED blinkt schnell	Ein Over-the-Air-Update wird ausgeführt.



DE

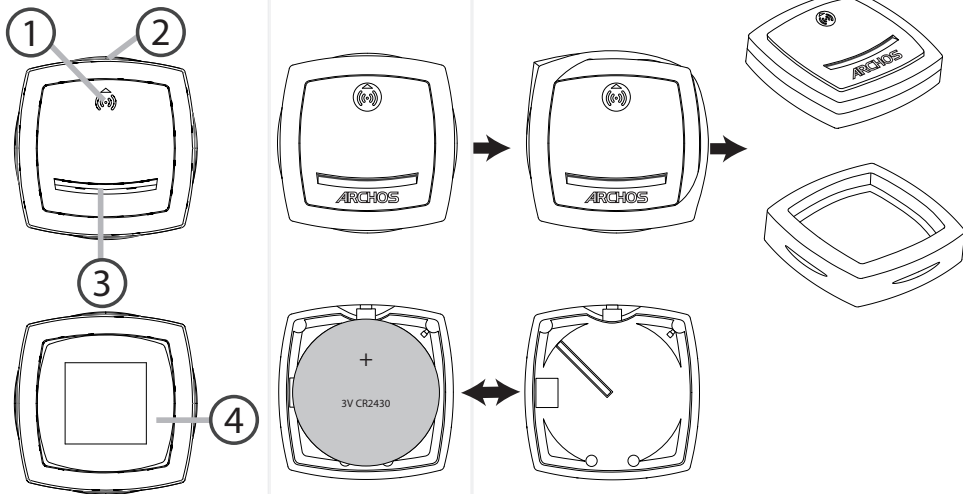



ARCHOS Movement Tag

Beschreibung von Movement Tag

- ① Magnet
- ② Magnetsensor
- ③ Magnetsensoranzeige
- ④ Paarungstaste
- ⑤ Paarungsanzeige
- ⑥ Gummigehäuse
- ⑦ Aufkleber

Installation von Movement Tag

Movement Tag wird mit einer Lithiumzelle CR 2430 betrieben.

1. Das Gummigehäuse vom Magnetempfänger entfernen.
2. Das Oberteil des hinteren Gehäuses abnehmen.
3. Den Isolationsaufkleber "Remove before use [Vor Verwendung entfernen]" entfernen.
4. Hinteres Gehäuse wieder befestigen.
5. Entfernen Sie den Aufkleber auf dem hinteren Gehäuse, um das Gerät an eine Wand oder Decke zu kleben.
6. Entfernen Sie den Aufkleber auf dem Zubehör, um es gegenüber der Magnetpositionsanzeige aufzukleben.

Bei langem Drücken der Paarungstaste (5 Sekunden)	LED blinkt 60 Sekunden	Das Gerät befindet sich im Paarungsmodus und versucht, zu einem Tablet zu verbinden.
Kurzes Drücken der Paarungstaste	LED blinkt 10 Sekunden	Das Gerät wurde bereits gepaart, ist aber getrennt. Es versucht, zu verbinden.
	LED blinkt dreimal	Das Gerät wurde nicht gepaart und ist getrennt.
	LED LEUCHTET 5 Sekunden	Das Gerät wurde gepaart und ist verbunden.
	LED blinkt schnell	Ein Over-the-Air-Update wird ausgeführt.

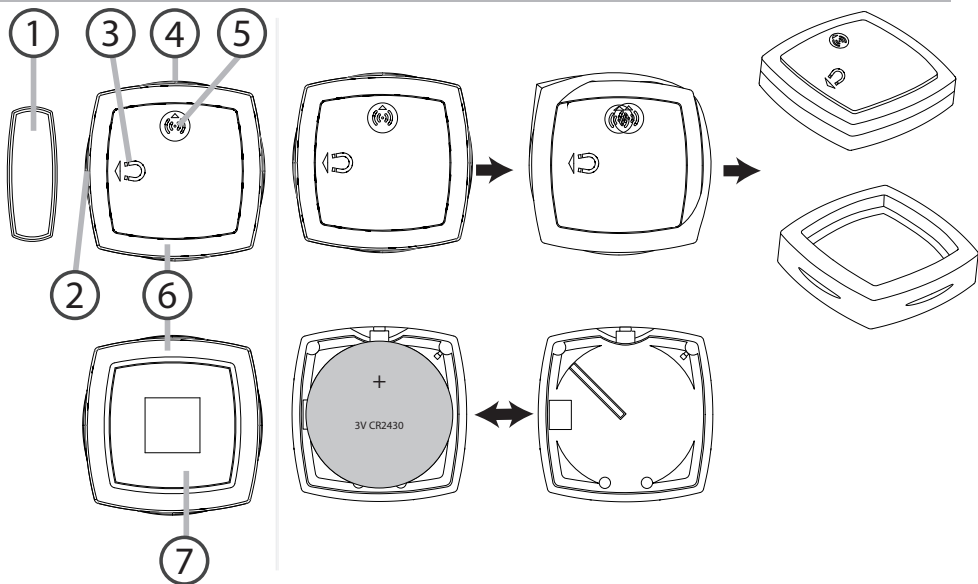

DE



Beschreibung des ARCHOS

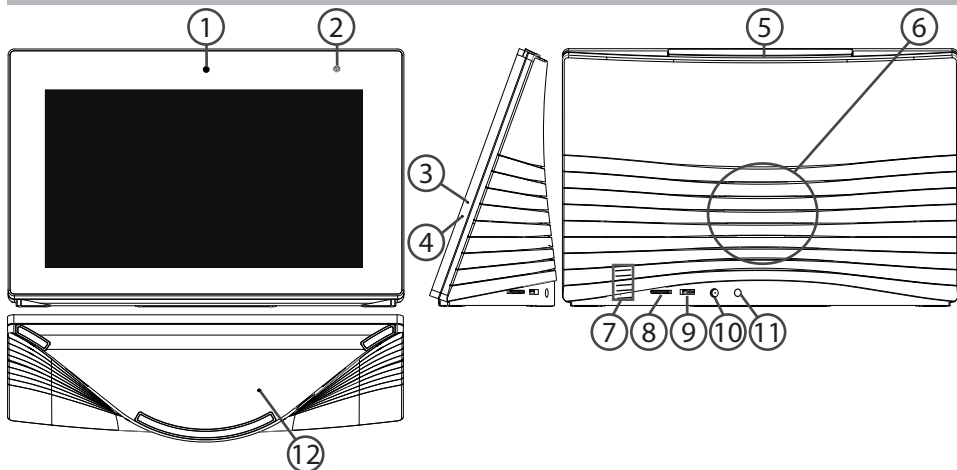

① Webcam

② Lichtsensor

③ Ladeanzeige

④ Mikrofon

⑤ EIN/AUS-Taste

⑥ Lautsprecher

⑦ Temperatursensor

⑧ Micro-SD Kartenslot

⑨ Micro-USB-Anschluss

⑩ Stromanschluss

⑪ Kopfhöreranschluss

⑫ Reset-Taste



Installationsassistent

DE

Wenn Sie Ihren ARCHOS das erste Mal in Betrieb nehmen, leitet Sie der Installationsassistent durch einige Bildschirme, um Ihnen dabei zu helfen, die grundlegenden Einstellungen vorzunehmen :

- Sprache
- WLAN Verbindung
- Einrichtung des Google-Kontos
- Standortdienst
- Anwendungen von Drittanbietern

TIPP:

Definieren Sie die Parameter des Gerätes für das WiFi (WLAN) Netzwerk, das Sie regelmäßig verwenden.



WiFi (WLAN) Verbindung

ACHTUNG: Stellen Sie sicher, dass Sie sich innerhalb einer WiFi(WLAN)-Zone aufhalten.



① Berühren und halten Sie die Symbole für Uhrzeit und Batterie, um die Statusleiste freizulegen. Es wird eine blaue Linie angezeigt.



② Ziehen Sie die blaue Linie nach unten, um das Status-Dashboard anzuzeigen.



③ Tippen Sie auf "Wi-Fi off [WLAN aus]" im Status-Dashboard. Die WLAN-Seite wird jetzt angezeigt.



④ Wenn "WLAN" deaktiviert ist, schieben Sie den WLAN-Schalter in die Position "EIN".

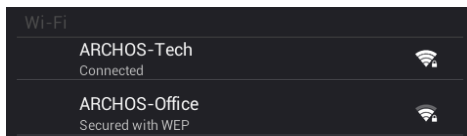

⑤ Sobald "WLAN" eingeschaltet ist, sucht der ARCHOS nach Netzwerken in Reichweite. Berühren Sie den Namen des Netzwerks, mit dem Sie verbunden werden möchten.

Gesicherte Netzwerke werden mit einem Schloß-Symbol angezeigt und erfordern die Eingabe eines Passworts.



Schnellverbindung

Verbinden Sie mit Ihrem WLAN-Netzwerk über das WiFi Protected Setup.

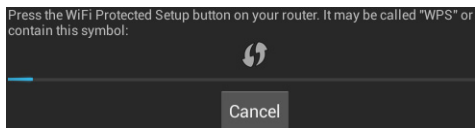

① Drücken Sie die Taste WiFi Protected Setup  unter Settings > Wireless & networks

② [Einstellungen > Drahtlos und Netzwerke]. Drücken Sie im Internet-Router die Taste WiFi Protected Setup, genannt WPS oder die Taste mit dem Symbol .

TIPPS:

- Bei der Eingabe eines WLAN-Passworts empfehlen wir die Auswahl von "Show password [Passwort anzeigen], damit die eingegebenen Zeichen sichtbar sind. Das korrekte WLAN-Passwort (oder die Einstellungen) für das Netzwerk erhalten Sie vom Netzanbieter Ihres WLANs. Ist Ihr WLAN eingeschaltet und Sie befinden sich im Bereich eines Netzwerks, mit dem Sie zuvor schon einmal verbunden waren, wird Ihr ARCHOS automatisch mit diesem Netzwerk Verbindung aufnehmen.
- Um die WLAN-Verbindung zu halten, während sich das Gerät im Standby-Modus befindet, wählen Sie das Menüsymbol auf der Seite "WLAN". Wählen Sie dann Advanced > Keep WiFi on during sleep > Always [Erweitert > WLAN Standby-Richtlinie > Immer].

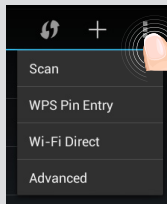



Die ARCHOS Home-Benutzeroberfläche

The screenshot displays the ARCHOS Home user interface on a tablet. At the top, there is a navigation bar with a home icon on the left, a room selection bar in the center (labeled '7'), and a window management icon on the right (labeled '8'). Below the navigation bar, the 'Rooms' section is visible, with 'KITCHEN' and 'LIVING' tabs. The 'LIVING' tab is active, showing a live camera feed of a person at a desk (labeled '11:59'), weather information (22.7° TEMPERATURE, 46% HUMIDITY), and movement tags ('Idle' and 'Closed'). A vertical sidebar on the left contains icons for home, settings, notifications, menu, mobile, and connectivity, numbered 1 through 6.



- ① **Register Rooms [Räume]:**
Anzeige der von Ihnen erstellten Räume, die den Räumen Ihres Hauses entsprechen.
- ② **Register Programs [Programme]:**
Anzeige der ohne die gepaarten Objekte erstellten Programme.
- ③ **Register All accessories [Zubehör]:**
Anzeige des mit dem Archos Smart Home Tablet gepaarten Zubehörs.
- ④ **Register History [Verlauf]:**
Anzeige des Aktionsverlaufs des jeweiligen Zubehörs.
- ⑤ **Register Connection [Verbindung]:**
Erlaubt Ihnen das Verbinden von Geräten und die Verwaltung des Home Tablets per Fernzugriff.
- ⑥ **Registerkarte General [Allgemein]:**
Erlaubt Ihnen das Hinzufügen von Benachrichtigungskonten und die Verwaltung der Einstellungen.
- ⑦ **Room displayed [Angezeigter Raum]:**
Anzeige des in diesem Raum platzierten Zubehörs. Nach rechts schieben für die Anzeige anderer Räume.
- ⑧ **Menüleiste:**
Anzeige kontextbezogener Menütasten entsprechend zum Register.



ARCHOS HOME - Erstmalige Einrichtung

Nach dem ersten Start der App müssen Räume erstellt werden. Die von Ihnen erstellten Räume müssen den tatsächlichen Räumen mit Zubehör entsprechen.

RÄUME

Erstellung eines Raums		
1	Starten Sie die Archos Home App	
2	Wählen Sie Add a room [Raum hinzufügen]	
3	Einen Namen für den Raum eingeben und OK wählen.	
Es können beliebig viele Räume erstellt werden.		
4	Sobald Sie fertig sind, Done [Fertig] wählen.	



PAARUNG

Nachdem Sie die Räume erstellt haben, muss das Zubehör mit Ihrem Tablet gepaart werden.

Paarung von Zubehör

1 Bluetooth muss im Tablet AKTIVIERT sein. Es kann über Settings > Wireless & Networks [Einstellungen > Drahtlos und Netzwerke] aktiviert werden.

2 Wählen Sie das gewünschte Zubehör.

Der Isolationsaufkleber "Remove before use [Vor Verwendung entfernen]" muss entfernt sein.

3 Halten Sie die Paarungstaste des Zubehörs 5 Sekunden lang gedrückt.

Die Paarungsanzeige beginnt zu blinken.

4 Drücken Sie die Start-Taste auf dem Tablet.

Der Paarungsvorgang beginnt.

Nach erfolgreicher Paarung wird die folgende Meldung angezeigt; **Paarung erfolgreich! OK drücken, um fortzufahren**

Successfully paired!
Press OK to continue

5 Wählen Sie OK.

Das Gerät kann mit einem vorhandenen Raum gepaart werden.



ARCHOS HOME - Erstmalige Einrichtung

Schlägt die Paarung fehl, erhalten Sie die folgende Nachricht:

Timeout
Press Cancel to continue

Ist Bluetooth im Tablet AKTIVIERT?

- 1 Wählen Sie im Tablet die App Settings [Einstellungen].
- 2 Im Bereich Wireless & Networks [Drahtlos & Netzwerke] Bluetooth neu starten.

Blinkt die Paarungsanzeige des Zubehörs?

Halten Sie die Paarungstaste des Zubehörs 5 Sekunden lang gedrückt, um sie einzuschalten.

Die Paarung neu starten.

TIPPS:

Bei langem Drücken der Paarungstaste (5 Sekunden)

LED blinkt 60 Sekunden lang: Das Gerät befindet sich im Paarungsmodus und versucht, zu einem Tablet zu verbinden.

Kurzes Drücken der Paarungstaste

LED blinkt 10 Sekunden lang: Das Gerät wurde bereits gepaart, ist aber getrennt. Es versucht, zu verbinden.

LED blinkt dreimal: Das Gerät wurde nicht gepaart und ist getrennt.

LED LEUCHTET 5 Sekunden lang: Das Gerät wurde gepaart und ist verbunden.

LED blinkt schnell: Ein Over-the-Air-Update wird ausgeführt.



BENENNUNG

Nach der Paarung muss ein Name für das Zubehör eingegeben werden.

Benennung eines Zubehörs

1 Geben Sie einen Namen für das Zubehör ein.

Es sollte ein Name ausgewählt werden, anhand dessen das Zubehör und dessen Position in Ihrem Haus auf einfache Weise identifiziert werden kann.

2 Wählen Sie OK.

VERBINDUNG

Nach der Benennung können die Räume ausgewählt werden, in denen das Gerät angezeigt werden soll.

Verlinkung eines Zubehörs mit einem Raum

1 Die ausgewählten Räume markieren.

2 Done [Fertig] wählen.

Nach der Durchführung der Einrichtung wird Ihr Zubehör in der Registerkarte All accessories [Zubehör] angezeigt.



Benutzeroberfläche Accessories [Zubehör]

Register All accessories [Zubehör]

The screenshot shows the 'Register All accessories' screen. At the top, there is a header with 'All accessories' and 'Sort by room'. Below this, there is a list of accessories. The first accessory is 'CamBall Mini-Cam' with a battery level of 39%, an 'Online' status, and a location of 'Living'. The second is 'Movement Tag' with a battery level of 90%, an 'Online' status, and a location of 'Living'. The third is 'Weather Weather Tag' with a battery level of 92%, an 'Online' status, and a location of 'Living'. A legend on the right side of the screen explains the icons and information shown:



①	Name des Bereichs
②	Art der Sortierung
③	Bluetooth-Verbindungsqualität
④	Weiteres Zubehör hinzufügen
⑤	- Ladezustand der Batterie - Verbindungsstatus - Betroffener Raum



Verwaltung des Zubehörs

DE



Wie kann ich weitere Räume erstellen?

- 1 Wählen Sie in der Archos Home App den Bereich Rooms [Räume] 
- 2 Wählen Sie im Bereich Rooms [Räume] das Symbol  in der Menüleiste.
- 3 Wählen Sie Add a room [Raum hinzufügen] und geben Sie den Namen des Raums ein.
Zum Abschließen Done [Fertig] wählen.

Rooms





Wie kann ich einen bereits erstellen Raum bearbeiten?

- 1 Wählen Sie in der Archos Home App den Bereich Rooms [Räume] .
- 2 Wählen Sie im Bereich Rooms [Räume] das Symbol  in der Menüleiste.
- 3 Wählen Sie neben einem vorhandenen Raum , um den Raum zu bearbeiten oder zu löschen.
- 4 Zum Abschließen Done [Fertig] wählen.



Verwaltung des Zubehörs

Wie kann ich weiteres Zubehör paaren?

- 1 Drücken Sie in der Archos Home App auf den Bereich All accessories [Zubehör] .
- 2 Wählen Sie im Bereich All accessories [Zubehör] das Symbol  in der Menüleiste.
- 3 Wählen Sie die Art des Zubehörs aus, das mit dem Tablet gepaart werden soll.

Der Isolationsaufkleber "Remove before use [Vor Verwendung entfernen]" muss entfernt sein.

- 4 Halten Sie die Paarungstaste des Zubehörs 5 Sekunden lang gedrückt.

Die Paarungsanzeige beginnt zu blinken.

- 5 Drücken Sie auf die Start-Taste auf dem Tablet.

Der Paarungsvorgang beginnt.

Wählen Sie OK bei erfolgreicher Paarung oder Restart [Neu starten] bei nicht erfolgreicher Paarung. Siehe vorheriger Zubehörbereich.

All accessories 

Accessories

Click on the accessory type you want to pair





Wie kann ich ein Zubehör umbenennen?

1 Drücken Sie in der Archos Home App auf den Bereich All accessories [Zubehör] .

2 Wählen Sie im Bereich All accessories [Zubehör] das umzubennende Zubehör  aus.

Eine Liste der Optionen wird angezeigt.

3 Wählen Sie Rename [Umbenennen] und dann OK.

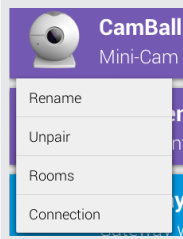

Wie kann ich ein Zubehör mit einem Raum verlinken?

1 Drücken Sie in der Archos Home App auf den Bereich All accessories [Zubehör] .

2 Wählen Sie im Bereich All accessories [Zubehör] das umzubennende Zubehör  aus.

Eine Liste der Optionen wird angezeigt.

3 Wählen Sie "Rooms [Räume]".

4 Wählen Sie die gewünschten Räume und dann OK.

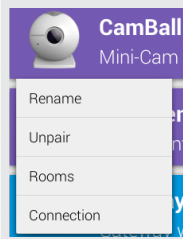



Verbindung zum Mobiltelefon

Das Archos Smart Home Tablet kann über ein Telefon oder Tablet per Fernzugriff verwaltet werden.

Herunterladen der App

- 1 Die Archos Home App kann im Play Store oder Appstore oder über den QR-Code heruntergeladen werden.
- 2 Nach dem Download die Anwendung starten.

Nach dem ersten Start der Anwendung stehen zwei Möglichkeiten für die Verbindung zu Ihrem Archos Smart Home Tablet zur Verfügung.

Verbindung im selben WLAN-Netzwerk.

- 1 Wählen Sie die Option **“if you are on the same home network than the Archos Home Gateway [ich befinde mich im selben Heimnetzwerk, wie das Archos Home Gateway]”**.



Die Nachricht **“Looking for the Archos Home Gateways in your local network [Suche nach Archos Home Gateways im lokalen Netzwerk]”** wird angezeigt. Sobald ein Archos Home Tablet in Ihrem Netzwerk gefunden wird, wird es angezeigt.

Drücken, um zu verbinden.



Eine Paarungsanforderung wird an das Home Tablet gesendet.

Wählen Sie **Allow [Erlauben]** im Home Tablet zur Autorisierung des Geräts.

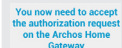



Die Verbindung wird aufgebaut. Sobald Ihr Gerät mit dem Home Tablet verbunden ist, kann Ihr Home Tablet von jedem Ort aus verwaltet werden.

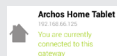

Verbindung über ein 3G-Netzwerk/ein anderes WLAN-Netzwerk

- 1 Wählen Sie die Option **"If you are on a remote connection [Keine Remote-Verbindung vorhanden]"**.



Für die Verbindung zum Home Tablet wird ein Code angefordert.

- 2 Starten Sie im Home Tablet die Archos Home App und wählen Sie das Register Connection [Verbindung].



- 3 Wählen Sie im Register Connection [Verbindung] **Authorize a device [Gerät autorisieren]** in der Menüleiste.

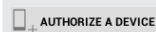

Ein 32-stelliger Schlüssel wird angezeigt. Dieser muss in das Gerät eingegeben werden, das Verbindung zum Home Tablet aufnehmen möchte.

- 4 Geben Sie den 32-stelligen Schlüssel ein.

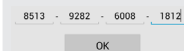

Die Verbindung wird aufgebaut. Sobald Ihr Gerät mit dem Home Tablet verbunden ist, kann Ihr Home Tablet aus der Entfernung verwaltet werden.

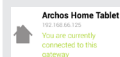



Programme





Nach der Paarung Ihres Zubehörs mit Ihrem Home Tablet können Programme erstellt werden. Ein Programm ist eine Aktion, die durch einen Auslöser gestartet und für einen bestimmten Zeitpunkt geplant wird.

Eine Programmoberfläche

	<ol style="list-style-type: none">1 Name des Programms2 Ein Auslöser ist ein Ereignis, das eine Reihe von Aktionen generiert3 Mit Duration [Dauer] wird das Zeitlimit einer Aktion festgelegt.4 Eine Action [Aktion] ist das Ergebnis eines auslösenden Ereignisses.5 Mit Schedule [Zeitplan] wird der Gültigkeitszeitraum der Aktionsfolge festgelegt.6 Mit Save [Speichern] wird das Programm bestätigt und Cancel [Abbrechen] wird die Erstellung verworfen.
--	--



Erstellung eines Programms

- 1 Starten Sie die Archos Home App .
 - 2 Drücken Sie in der Archos Home App auf das Register Programs [Programme] .
 - 3 Wählen Sie  in der Menüleiste.
- Ein Fenster für die Erstellung eines Programms wird angezeigt.
- 4 Geben Sie einen Namen ein.
 - 5  : Dieser kann Zeitplan, Erkennung oder Wetterereignis sein.
 - 6  : Dieser kann Benachrichtigung, Schnappschuss oder Video sein. Es kann eine Dauer für die Aktion festgelegt werden.
 - 7 Legen Sie einen Zeitraum fest, wann das Ereignis auftritt.
 - 8 Wählen Sie **SAVE [SPEICHERN]**.

Das Programm ist jetzt erstellt und aktiv.

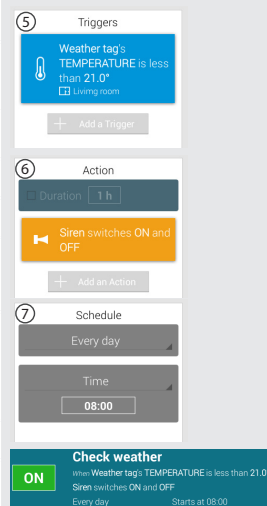

5 Triggers

Weather tag's TEMPERATURE is less than 21.0°
 Living room

+ Add a Trigger

6 Action

Duration | 1 h

Siren switches ON and OFF

+ Add an Action

7 Schedule

Every day

Time

08:00

Check weather

ON when Weather tag's TEMPERATURE is less than 21.0°
Siren switches ON and OFF
Every day Starts at 08:00



Programme

Änderung eines Programms

- 1 Starten Sie die Archos Home App .
 - 2 Drücken Sie in der Archos Home App auf das Register Programs [Programme] .
 - 3 Wählen Sie das zu ändernde Programm aus.
- Es werden Optionen für das Programm angezeigt.
- 4 Wählen Sie Edit [Bearbeiten].
 - 5 Die gewünschten Änderungen durchführen.
 - 6 Wählen Sie **SAVE [SPEICHERN]**.

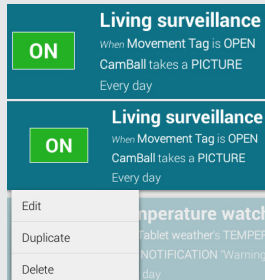



ON Living surveillance
When Movement Tag is OPEN
CamBall takes a PICTURE
Every day

ON Living surveillance
When Movement Tag is OPEN
CamBall takes a PICTURE
Every day

Edit temperature watch
Duplicate Tablet weather's TEMPER
Delete NOTIFICATION Warning
day

Ein Programm ein-/ausschalten

- 1 Starten Sie die Archos Home App .
 - 2 Drücken Sie in der Archos Home App auf das Register Programs [Programme] .
 - 3 Wählen Sie das zu aktivierende Programm aus.
 - 4 Drücken Sie **ON**, um das Programm auszuschalten **OFF**.
- Drücken Sie **OFF**, um es wieder einzuschalten **ON**.



ARCHOS Home Interaktionen

DE

Ihr Zubehör wird mit Ihrem Home Tablet gepaart. Die Daten der jeweiligen Zubehörgeräte werden im Tablet angezeigt.



Auf Ihrem Tablet erstellte Programme erzeugen Interaktionen zwischen Tablet und Zubehör.
In der Registerkarte Rooms [Räume] entspricht jeder Informationsbereich einem spezifischen Zubehör.



Tippen Sie auf einen Bereich für die Anzeige der Verlaufsdaten.

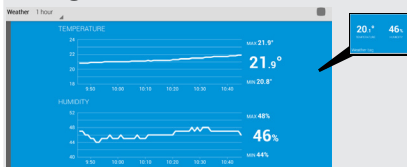

Ihr Telefon unterstützt Sie mithilfe der Anwendung Archos Home bei der Verwaltung Ihres Tablets und des Zubehörs per Fernzugriff.



101



Die Android™ Benutzeroberfläche

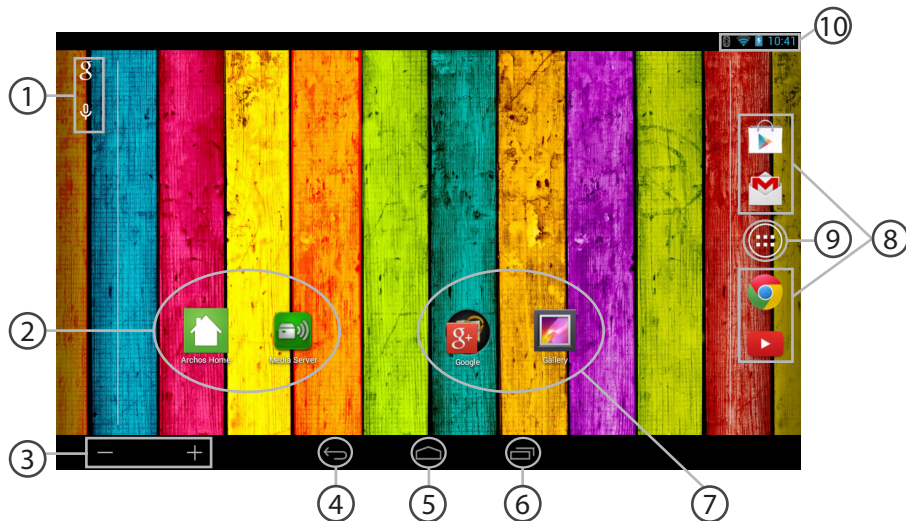



- ① **Google™ Suche**
> Suchbegriff eintippen oder Spracheingabe verwenden.
- ② **ARCHOS-Apps**
- ③ **Lautstärketasten**
- ④ **“Zurück”**
- ⑤ **“Startbildschirm”**
- ⑥ **“Letzte Apps”**
- ⑦ **Verknüpfungen für Google-Apps**
> Tippen für den Start einer Anwendung.
- ⑧ **Permanenten Android™ Apps-Verknüpfungen**
- ⑨ **" Alle Apps"**
> Berühren Sie dieses Symbol, um alle auf Ihrem ARCHOS installierten Apps und Widgets anzuzeigen. Alle heruntergeladenen Anwendungen befinden sich hier.
- ⑩ **Statusleiste**
> Auf der Statusleiste werden Benachrichtigungen und die Systemsymbole angezeigt.



Die Android™ Benutzeroberfläche

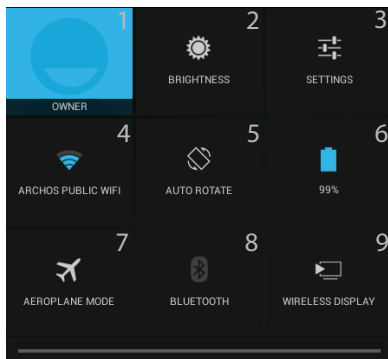

3:18 Schnelleinstellungen

- 1 Aktueller Benutzer⁽¹⁾
- 2 Einstellung der Bildschirmhelligkeit.
- 3 Zugriff auf alle Einstellungen.
- 4 Ein- und Ausschalten der WLAN-Verbindung.
- 5 Ermöglicht die Aktivierung und Deaktivierung der automatischen Display-Drehung.
- 6 Akkurestlaufzeit in Prozent
- 7 Beendet alle WLAN-Verbindungen, nützlich für Flugreisen.
- 8 Sie können Bluetooth-Schnittstelle sehen
- 9 Wireless Display aktivieren⁽²⁾

⁽¹⁾Mit dem neuen Multi-User-Support für Tablets besitzt jeder Benutzer seinen eigenen separaten und anpassbaren Bereich auf einem einzelnen Gerät. Benutzer können unter Settings > Device [Einstellungen > Gerät] hinzugefügt werden.

⁽²⁾Sie können Filme, YouTube-Videos und alles, was sich auf Ihrem Bildschirm befindet, auf einem HDTV teilen. Sie müssen ein Wireless Display-Adapter an einen HDMI-fähigen Fernseher anschließen, um so schnell und einfach den Inhalt Ihres Bildschirms wiederzugeben.



Letzte Apps

Öffnet eine Liste mit Mini-Abbildungen der kürzlich verwendeten Apps:

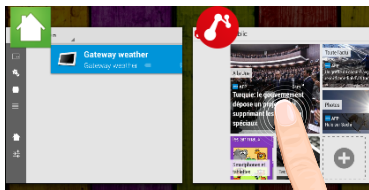

Tippen: öffnen einer Anwendung.

Länger drücken: Anzeige von Optionen

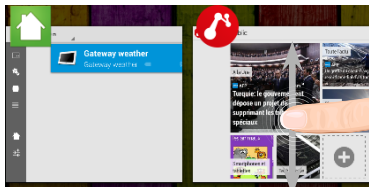

Nach oben oder unten wischen: Eine Anwendung schließen.



Android™ kennenlernen

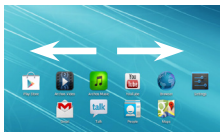

Der erweiterte Startbildschirm:

Wechseln Sie durch Wischen nach links und rechts zwischen verschiedenen «Home»-Bildschirmen.

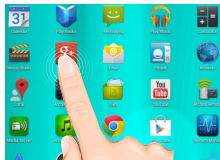

Ein Element vom Startbildschirm verschieben:

Zum Verschieben eines Elements vom Startbildschirm den Finger darauf legen und so lange halten, bis die Rasterlinien zur Positionierung erscheinen. Dann an die gewünschte Stelle schieben und loslassen.

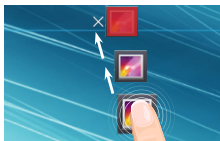

Ein Element vom Startbildschirm entfernen:

Den Finger auf das Element legen und halten. Den Finger auf dem Bildschirm nach oben bewegen und über dem «Entfernen»-Symbol loslassen.

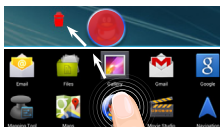

Ein Element deinstallieren:

Auf den «Alle Apps»-Bildschirmen das betreffende Element berühren und halten. Den Finger im Bildschirm nach oben bewegen und über dem «Deinstallieren»-Papierkorb loslassen.

Anwendungsordner erstellen:

Ziehen Sie auf einem Startbildschirm ein Anwendungssymbol über



ein anderes. Die beiden Symbole werden kombiniert.

Widgets:

Berühren Sie das «Alle Apps»-Symbol auf dem Startbildschirm.



Berühren Sie «Widgets» oben auf dem Bildschirm. Auf dem «Widgets»-Hauptbildschirm können Sie Widgets genau wie Anwendungssymbole auch verschieben.

Hintergrundbild ändern:

Den Finger auf eine freie Stelle des Bildschirms legen und dann

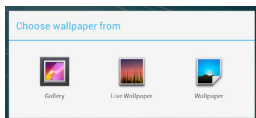

aus der Liste auswählen.

Touchscreen sperren:

Berühren Sie Einstellungen auf dem Schnelleinstellungen-Dashboard in der Statusleiste. Scrollen Sie nach unten und

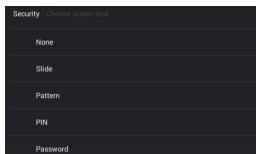

berühren Sie "Sicherheit". Berühren Sie Bildschirmssperrung. Berühren Sie die gewünschte Art der Sperrung. Nach erfolgter Sperrung wird ein Sperrbildschirm angezeigt, sobald der Bildschirm aktiviert wird. Auf diesem ist ein Muster, eine PIN oder ein anderer festgelegter Schlüssel einzugeben.



Fehlersuche

Was kann ich bei einer Bluetooth-Fehlfunktion tun?

Gehen Sie zu Settings > Wireless & Networks [Einstellungen > Drahtlos & Netzwerke] und wählen Sie Bluetooth. Markieren Sie Bluetooth, um Bluetooth zu aktivieren.

Bluetooth

Click to restart Bluetooth

Warum ist eine Verbindung vom Home Tablet zum Mobiltelefon nicht möglich?

Bei der Verbindung könnte es sich um ein geschütztes Netzwerk mit Firewall handeln. In diesem Fall ist eine Verbindung zu Ihrem Home Tablet nicht möglich.

Warum reagiert mein Zubehör nicht?

Wurde es ordnungsgemäß mit Ihrem Home Tablet gepaart?

Bluetooth muss im Tablet AKTIVIERT sein.

Den Ladezustand der Batterien überprüfen. Bei leeren Batterien diese ersetzen.

Warum kann ich kein weiteres Zubehör hinzufügen?

Es kann eine Höchstmenge von 13 Zubehörteilen mit Ihrem Home Tablet verbunden werden.

Ist diese Menge noch nicht erreicht, Bluetooth im Tablet aktivieren und den Ladezustand der Batterien überprüfen.

Wie kann ich mein Gerät auf die Standardeinstellungen zurücksetzen?

1. Bei ausgeschaltetem Gerät das Stromkabel in den Stromanschluss stecken.
2. Sobald das ARCHOS Bootlogo angezeigt wird, die Reset-Taste 5 Sekunden lang mit dem Ende einer Büroklammer gedrückt halten.

Die Android-Wiederherstellungsoberfläche wird angezeigt.

3. Wählen Sie mit Ihrem Finger eine Option aus.
4. Mit der EIN-/AUS-Taste bestätigen.
 - "Wipe Data/Factory Reset [Daten löschen/Werkseinstellung]" wählen und bestätigen, um Ihr Gerät auf die Standardeinstellungen zurückzusetzen.
 - "Yes -- delete all user data [Ja -- alle Benutzerdaten löschen]" wählen und bestätigen, um so alle Benutzerdaten zu entfernen.
 - "Reboot System now [System jetzt neu starten]" wählen und bestätigen, um das Gerät neu zu starten.



Índice

Contenido de la caja.....	110
Inicio.....	111
Mini cámara ARCHOS.....	112
Etiqueta de tiempo ARCHOS.....	114
Etiqueta de movimiento ARCHOS.....	116
Descripción de ARCHOS Smart Home Tablet.....	118
Introducción al asistente.....	119
Conexión a una red WiFi.....	120
Interfaz de ARCHOS Home.....	122
ARCHOS HOME - Configuración Inicial.....	124
Interfaz de accesorios.....	128
Gestión de accesorios.....	129
Conexión a la Home Tablet.....	132
Programas.....	134
Interacción con ARCHOS Home.....	137
La interfaz Android™.....	138
Familiarizarse con Android™.....	142
Resolución de problemas.....	144

Para obtener más información, consulte la sección de preguntas frecuentes en la dirección www.archos.com. Asegúrese de leerlos antes de considerar devolver el producto.



Contenido de la caja

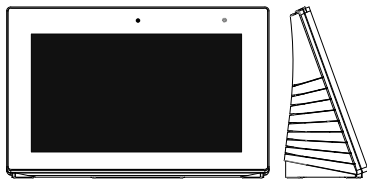

ARCHOS Smart Home Tablet



Mini Cam
X 2



Weather Tag
X 2



Movement Tag
X 2



Cable USB



Cargador



Guía de usuario



Avisos de garantía,
legales y de seguridad



Procedimientos iniciales

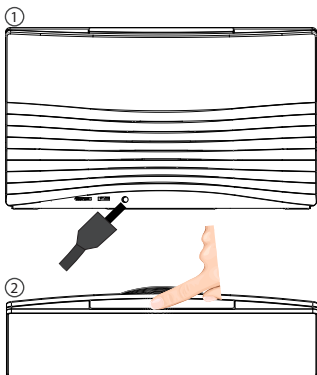

1. Conecte el cable de alimentación al conector de alimentación. La luz del piloto de alimentación es azul cuando el cable de alimentación está conectado. El dispositivo empezará a cargarse.
2. Pulse el botón ON/OFF para encender el dispositivo.
 - Puede utilizar el ARCHOS mientras se carga.
 - Deje cargar completamente el dispositivo la primera vez que lo utilice.
 - Utilice únicamente el cargador suministrado.



Su dispositivo debe permanecer conectado al conector de alimentación siempre que sea posible.

CONSEJOS:

Para recibir una asistencia más completa, registre su producto.
Con un ordenador, vaya a www.archos.com/register.



ARCHOS Mini Cam

Descripción de la mini cámara

- 1 Botón de emparejamiento
- 2 Indicador de emparejamiento
- 3 Lente de la cámara
- 4 Micrófono
- 5 Adhesivo

Instalación de la mini cámara

La cámara funciona con 3 pilas de litio CR 24 50.

1. Desatornille la esfera de la cámara.
2. Retire la etiqueta aislante "remove before use".
3. Vuélvala a atornillar.
4. Coloca la cámara en su base.

La cámara se mantiene estable gracias a unos imanes que permiten moverla para apuntar en cualquier dirección.

5. Retire el adhesivo de la base para fijar el dispositivo a una pared o techo.

Mantener pulsado el botón de emparejamiento (5 segundos)	El LED parpadea durante 60 segundos	El dispositivo está en modo emparejamiento intentando conectarse a la tableta.
Pulsar brevemente el botón de emparejamiento	El LED parpadea durante 10 segundos	Dispositivo emparejado pero aún sin conectar. Intentando conectarse.
	El LED parpadea tres veces	El dispositivo no está emparejado ni conectado.
	El LED se enciende durante 5 segundos	Dispositivo emparejado y conectado.
	El LED parpadea rápido	Se está actualizando de forma inalámbrica.

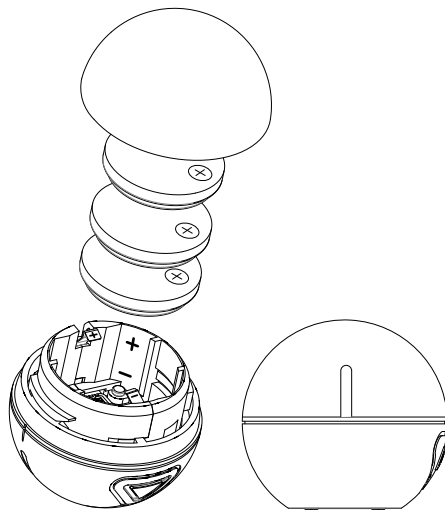
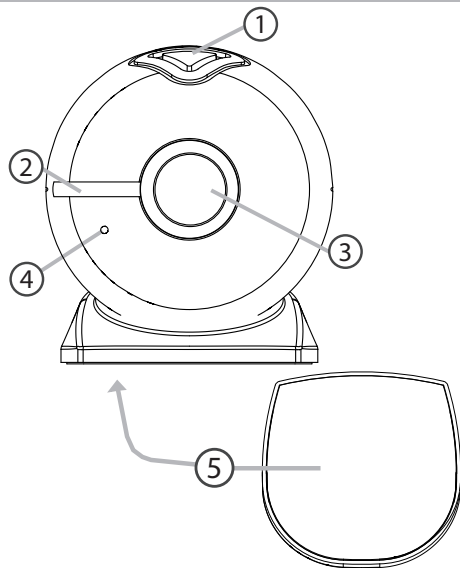

ES



ARCHOS Weather Tag

Descripción de la etiqueta de Tiempo

- 1 Botón de emparejamiento
- 2 Indicador de emparejamiento
- 3 Abrir
- 4 Adhesivo

Instalación de la etiqueta de Tiempo

La etiqueta de Tiempo funciona con una pila de litio CR 24 30.

1. Retire el protector de goma.
2. Separe la parte superior de la cubierta posterior.
3. Retire la etiqueta aislante "remove before use".
4. Vuelva a colocar la cubierta posterior y la goma.
5. Retire el adhesivo de la parte posterior para fijar el dispositivo a una pared.

Mantener pulsado el botón de emparejamiento (5 segundos)	El LED parpadea durante 60 segundos	El dispositivo está en modo emparejamiento intentando conectarse a la tableta.
Pulsar brevemente el botón de emparejamiento	El LED parpadea durante 10 segundos	Dispositivo emparejado pero aún sin conectar. Intentando conectarse.
	El LED parpadea tres veces	El dispositivo no está emparejado ni conectado.
	El LED se enciende durante 5 segundos	Dispositivo emparejado y conectado.
	El LED parpadea rápido	Se está actualizando de forma inalámbrica.

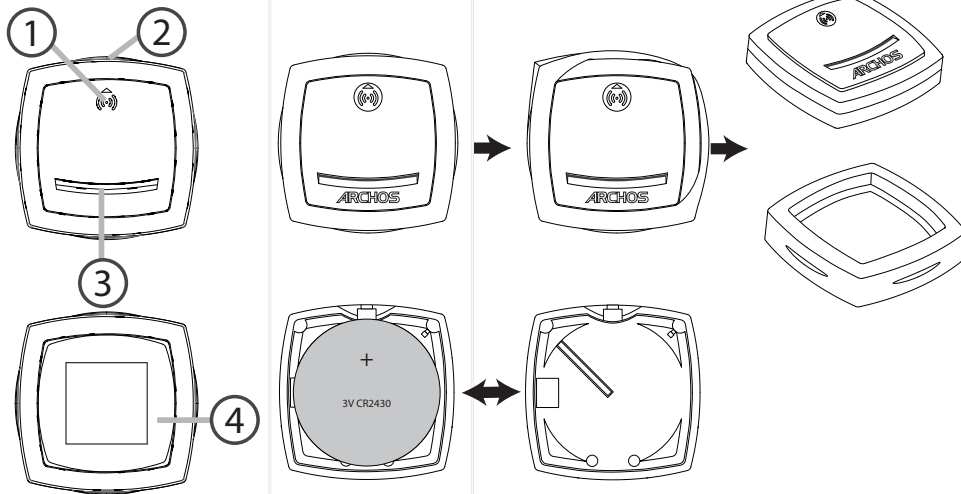

ES



ARCHOS Movement Tag

Descripción de la etiqueta de Movimiento

- 1 Imán
- 2 Sensor magnético
- 3 Indicador del sensor magnético
- 4 Botón de emparejamiento
- 5 Indicador de emparejamiento
- 6 Protector de goma
- 7 Adhesivo

Instalación de la etiqueta de Movimiento

La etiqueta de Movimiento funciona con una pila de litio CR 24 30.

1. Retire el protector de goma del receptor magnético.
2. Separe la parte superior de la cubierta posterior.
3. Retire la etiqueta aislante "remove before use".
4. Vuelva a colocar la cubierta posterior.
5. Retire el adhesivo de la parte posterior para fijar el dispositivo a una pared.
6. Retire el al adhesivo de los accesorios para fijarlo frente al indicador de posición del imán.

Mantener pulsado el botón de emparejamiento (5 segundos)	El LED parpadea durante 60 segundos	El dispositivo está en modo emparejamiento intentando conectarse a la tableta.
Pulsar brevemente el botón de emparejamiento	El LED parpadea durante 10 segundos	Dispositivo emparejado pero aún sin conectar. Intentando conectarse.
	El LED parpadea tres veces	El dispositivo no está emparejado ni conectado.
	El LED se enciende durante 5 segundos	Dispositivo emparejado y conectado.
	El LED parpadea rápido	Se está actualizando de forma inalámbrica.

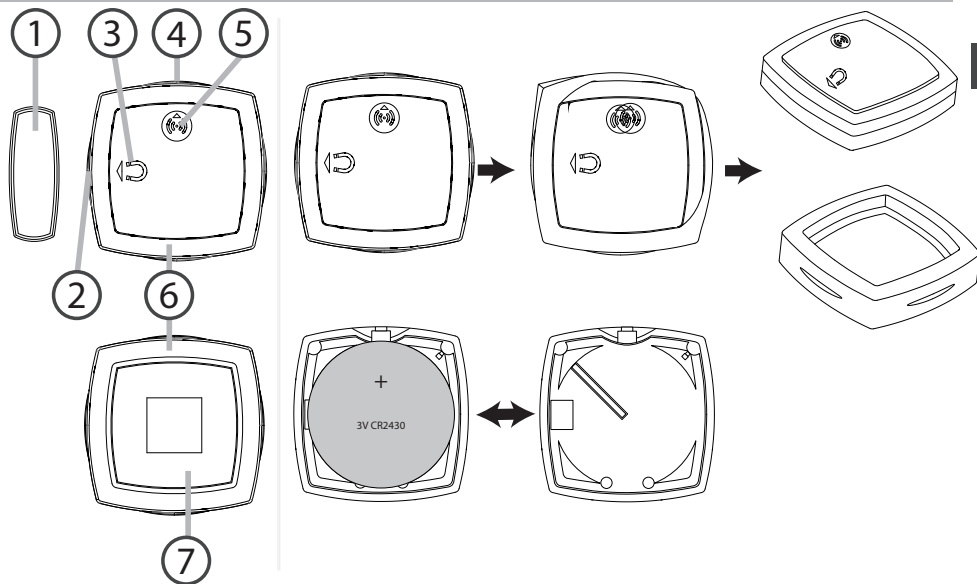



Descripción del ARCHOS

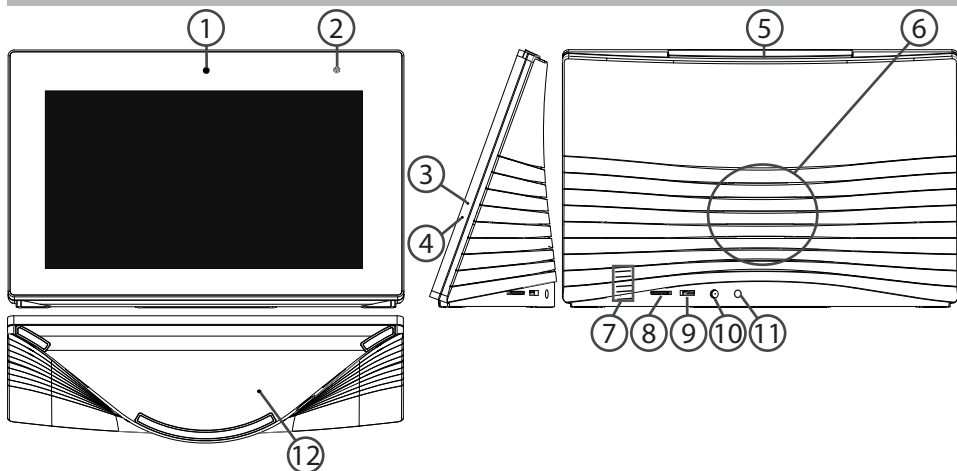

- | | | | |
|----------------------|----------------|---------------------------------|----------------------------|
| ① Webcam | ④ Micrófono | ⑦ Sensor de temperatura | ⑩ Conector de alimentación |
| ② Sensor de luz | ⑤ Botón ON/OFF | ⑧ Ranura para tarjetas Micro-SD | ⑪ Toma de auriculares |
| ③ Indicador de carga | ⑥ Altavoz | ⑨ Puerto micro USB | ⑫ Botón de restablecer |



Asistente de inicio

La primera vez que encienda el ARCHOS, el asistente de instalación le ayudará a configurar el dispositivo :

- Idioma
- Conexión WiFi
- Configuración de cuenta de Google
- El servicio de ubicación
- Aplicaciones de terceras partes

ES

CONSEJOS:

Definir los parámetros de su dispositivo en el área de la red WiFi que usted será regularmente usando.



Conexión WiFi

ADVERTENCIA: Asegúrese de que se encuentra en una zona WiFi.

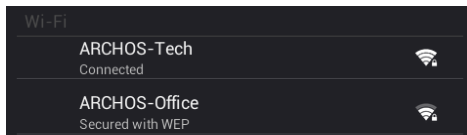

① Mantenga pulsados los iconos de reloj y batería para mostrar la barra de estado. Aparecerá una franja azul.

② Arrastre la franja azul hacia abajo para mostrar el panel de estado.

③ Pulse "Wi-Fi off [Desactivar WiFi]" en el panel de estado. Aparecerá la página WiFi.

④ Si el sistema WiFi está desactivado, deslice el interruptor WiFi para ajustarlo en la posición "ON".

⑤ Una vez activado el sistema WiFi, el ARCHOS buscará redes WiFi que se encuentren dentro de su alcance. Toque el nombre de la red a la que desee conectarse.

Las redes privadas se muestran con un icono de candado y será preciso que introduzca su contraseña.



Conexión rápida

Puede conectarse a su red WiFi a través de una configuración protegida WiFi.

Press the WiFi Protected Setup button on your router. It may be called "WPS" or contain this symbol:

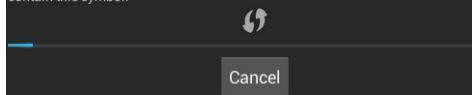

① Pulse el botón de Configuración protegida WiFi  en Ajustes > Conexiones

② inalámbricas y redes.

En su router de Internet, pulse el botón de Configuración protegida WiFi llamado WPS o que contiene el símbolo .

CONSEJOS:

- Al introducir la contraseña WiFi, le recomendamos que seleccione "Mostrar contraseña" para poder ver lo que escribe. Póngase en contacto con su proveedor de acceso WiFi para conocer la contraseña (o los ajustes) WiFi de la red. Si la WiFi está encendida y usted se encuentra dentro del área de cobertura de la red, a la que ya se ha conectado con anterioridad, el ARCHOS intentará conectarse automáticamente a ella.
- Para mantener la conexión WiFi activada con el dispositivo en reposo, seleccione el icono de menú en la página "WiFi". Luego, seleccione Avanzado > Mantener WiFi activo durante el periodo de reposo > Siempre.

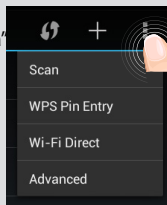



Interfaz de ARCHOS HOME

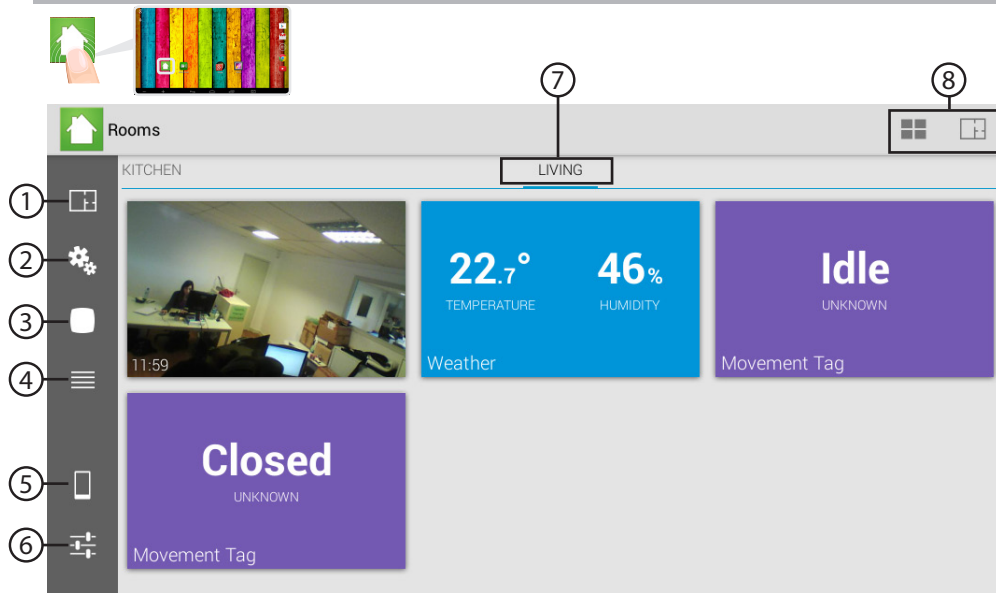



- ① **Pestaña Habitaciones:**
muestra las habitaciones creadas correspondientes a las habitaciones de su casa.
- ② **Pestaña Programas:**
muestra los programas creados con los objetos emparejados.
- ③ **Pestaña Todos los accesorios:**
muestra todos los accesorios emparejados con la Archos Smart Home Tablet.
- ④ **Pestaña Historial:**
muestra el historial de acciones de los distintos accesorios.
- ⑤ **Pestaña Conexión:**
permite conectar dispositivos y gestionar la home tablet a distancia.
- ⑥ **Pestaña General:**
permite añadir notificaciones y gestionar los parámetros.
- ⑦ **Habitación mostrada:**
muestra los accesorios instalados en esa habitación. Desplácese a la derecha para ver otras habitaciones.
- ⑧ **Barra de menú:**
muestra los botones del menú contextual correspondiente a la pestaña.



ARCHOS HOME - Configuración Inicial

La primera vez que abra la aplicación se le pedirá que cree sus habitaciones, que deberán corresponder a las habitaciones de la casa donde coloque los accesorios.

HABITACIONES

Para crear una habitación

- 1 Abra la aplicación Archos Home.
 - 2 Seleccione "Add a room" (Añadir habitación).
 - 3 Teclee un nombre para la habitación y pulse "OK" (Aceptar).
- Puede crear cuantas habitaciones quiera.
- 4 Una vez terminado, pulse "Done" (Hecho).



Rooms



Add a room

Done



EMPAREJAMIENTO

Una vez las habitaciones creadas, en el siguiente paso emparejará los accesorios con su tableta.

Para emparejar un accesorio

1 Compruebe que el Bluetooth de la tableta está activado. Si no es así, actívalo en Ajustes > Conexiones inalámbricas y redes.

2 Seleccione el accesorio deseado.

Asegúrese de retirar la etiqueta aislante "remove before use" en las pilas.

3 Pulse el botón de emparejamiento del accesorio durante 5 segundos.

El indicador de emparejamiento empezará a parpadear.

4 Pulse el botón "Start" (Iniciar) en la tableta

para iniciar la conexión entre dispositivos.

Si el emparejamiento se realiza correctamente, aparecerá el siguiente mensaje: **"Successfully paired! Press OK to continue" (Emparejamiento correcto, pulse Aceptar para continuar)**

Successfully paired!
Press OK to continue

5 Pulse "OK" (Aceptar).



ARCHOS HOME - Configuración Inicial

Se le pedirá que vincule el dispositivo con una habitación de casa.

Si hay un error en el proceso de emparejamiento, aparecerá el siguiente mensaje:

Timeout
Press Cancel to continue

Compruebe si el Bluetooth de la tableta está activado.

1 Seleccione Ajustes en la tableta.

2 En la sección Conexiones inalámbricas y redes, reinicie Bluetooth.

Compruebe si el indicador de emparejamiento del accesorio parpadea.

Para encenderlo, pulse el botón de emparejamiento del accesorio durante 5 segundos.

Vuelva a iniciar el emparejamiento.

CONSEJOS:

Mantener pulsado el botón de emparejamiento (5 segundos)

El LED parpadea durante 60 segundos: El dispositivo está en modo emparejamiento intentando conectarse a la tableta.

Pulsar brevemente el botón de emparejamiento

El LED parpadea durante 10 segundos: Dispositivo emparejado pero aún sin conectar. Intentando conectarse.

El LED parpadea tres veces: El dispositivo no está emparejado ni conectado.

El LED se enciende durante 5 segundos: Dispositivo emparejado y conectado.

El LED parpadea rápido: Se está actualizando de forma inalámbrica.



NOMBRAR

Tras el emparejamiento, deberá asignar un nombre a cada accesorio.

Para nombrar un accesorio

1 Introduzca un nombre correspondiente al accesorio.

Pruebe a utilizar un nombre que le ayude a identificar fácilmente el accesorio y su posición dentro de casa.

2 Pulse "OK" (Aceptar).

VINCULAR

Hecho esto, seleccione las habitaciones en las que quiere mostrar el dispositivo.

Para vincular un accesorio a una habitación

1 Marque la habitación o habitaciones escogidas.

2 Pulse en "Done" (Hecho).

Una vez terminada la configuración, sus accesorios aparecerán en la pestaña Todos los accesorios.



Interfaz de accesorios

Pestaña Todos los accesorios

① All accessories Sort by room ③ ④

① Living ②

CamBall
Mini-Cam ⑤
39% Online Living

Movement Tag
Movement Tag 90% Online Living



Weather
Weather Tag 92% Online Living

- ① Nombre de la sección
- ② Ordenar por
- ③ Calidad de la conexión Bluetooth
- ④ Añadir más accesorios
- ⑤
 - Nivel de batería
 - Estado de conexión
 - Habitación donde está



Gestión de accesorios

¿Cómo puedo crear más habitaciones?



- 1 En la aplicación Archos Home, seleccione la sección Habitaciones 
- 2 En la sección Habitaciones, seleccione el icono Habitaciones  en la barra de menú.
- 3 Seleccione "Add a room" (Añadir a habitación) y "type" (tipo) en el nombre de la habitación.
Seleccione "Done" (Hecho) una vez terminado.

Rooms



ES



¿Cómo hago para modificar una habitación ya creada?

- 1 En la aplicación Archos Home, seleccione la sección Habitaciones.
- 2 En la sección Habitaciones, seleccione el icono  en la barra de menú.
- 3 Junto al nombre de las habitaciones existentes, seleccione  para modificar o borrar la habitación.
- 4 Seleccione "Done" (Hecho) una vez terminado.



Gestión de accesorios

¿Cómo hago para emparejar más accesorios?

- 1 En la aplicación Archos Home, seleccione la sección Todos los accesorios 
- 2 En la sección Todos los accesorios, seleccione el icono  en la barra de menú.
- 3 Seleccione el tipo de accesorio que desea emparejar con la tableta.

Asegúrese de retirar la etiqueta aislante "remove before use" en las pilas.

- 4 Pulse el botón de emparejamiento del accesorio durante 5 segundos.

El indicador de emparejamiento empezará a parpadear.

- 5 Pulse el botón "Start" (Iniciar) en la tableta

para iniciar la conexión entre dispositivos.

Seleccione "OK" (Aceptar) si la conexión es correcta. De lo contrario, pruebe de nuevo. Consulte la sección anterior sobre accesorios.

All accessories 

Accessories

Click on the accessory type you want to pair





¿Cómo puedo cambiar el nombre de un accesorio?

1 En la aplicación Archos Home, seleccione la sección Todos los accesorios .

2 En la sección Todos los accesorios, seleccione el accesorio  al que quiera cambiar de nombre.

Aparecerá una lista de opciones.

3 Seleccione "Rename" (Cambiar de nombre) y luego "OK" (Aceptar).

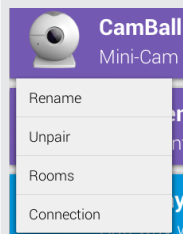

¿Cómo puedo vincular un accesorio a una habitación?

1 En la aplicación Archos Home, seleccione la sección Todos los accesorios .

2 En la sección Todos los accesorios, seleccione el accesorio  al que quiera cambiar de nombre.

Aparecerá una lista de opciones.

3 Seleccione "Rooms" (Habitaciones).

4 Seleccione las habitaciones que quiera y pulse "OK" (Aceptar).

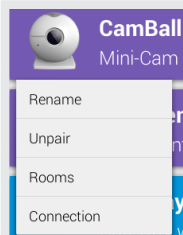



Conexión con un teléfono móvil

Cuando no este en casa, puede manejar su Archos Smart Home Tablet desde un teléfono móvil o una tableta.

Descargar la aplicación

- 1 Descargue la aplicación Archos Home en la Play Store o la Appstore o capturando el código QR.
- 2 Una vez descargada, abra la aplicación.

La primera vez que abra la aplicación, se le mostrarán dos opciones para conectar su Archos Smart Home Tablet.

Conexión a través de la misma red WiFi

- 1 Seleccione la opción **“if you are on the same home network than the Archos Home Gateway”** (si se encuentra en la misma red doméstica que el Archos Home Gateway).



Aparecerá el mensaje **“Looking for the Archos Home Gateways in your local network”** (buscando Archos Home Gateways en su red local). Una vez localizada, aparecerá la Archos Home tablet en su red.

Pulse para conectar.



Se enviará una solicitud de emparejamiento a la Home Tablet.

Seleccione **Permitir** en la Home Tablet para autorizar el dispositivo.

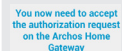



La conexión está en curso. Una vez conectado el dispositivo a la Home Tablet, podrá manejar su home tablet desde cualquier lugar.

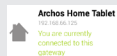

Conexión a través de la red 3G u otra red WiFi

1 Seleccione la opción **"If you are on a remote connection"** (si está utilizando una conexión remota).



Se le pedirá un código para conectarse a la Home Tablet.



2 En la Home Tablet, abra la aplicación Archos Home y seleccione la Pestaña Conexión.



3 En la pestaña Conexión, seleccione **Authorize a device** (Autorizar un dispositivo) en la barra de menú.

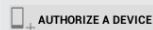

Se le proporciona una clave de 32 dígitos que deberá introducir en el dispositivo que intente conectarse a la Home Tablet.

4 Introduzca la clave de 32 dígitos en los campos de código requerido.

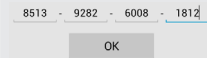

La conexión está en curso. Una vez conectado el dispositivo a la Home Tablet, podrá manejar su home tablet a distancia.

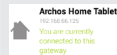



Programas





Podrá empezar la creación de programas cuando sus accesorios estén emparejados con la Home Tablet. Un programa es una acción activada por un desencadenante y programada para unas fechas determinadas.

Interfaz de un programa

- ① Nombre del programa
- ② Un desencadenante es un evento que crea una secuencia de acciones
- ③ La duración es el límite temporal de la acción
- ④ Una acción es el resultado del evento desencadenado
- ⑤ La fecha especifica el periodo de validez para una secuencia de acciones
- ⑥ "Save" (Guardar) para validar el programa y "Cancel" (Cancelar) para salir sin crear ningún programa.



Para crear un programa

- 1 Abra la aplicación Archos Home .
 - 2 En la aplicación Archos Home , seleccione la pestaña Programas .
 - 3 Seleccione  en la barra de menú.
- Aparecerá una ventana para la creación de programas
- 4 Introduzca un nombre.
 - 5  : puede ser una fecha, una detección, un fenómeno meteorológico.
 - 6  : puede ser una notificación, una foto, un vídeo. Puede fijar una duración para la acción.
 - 7 Establezca las fechas en las que ocurrirá el evento.
 - 8 Seleccione **SAVE** (Guardar)

El programa ya está creado y listo para usar.

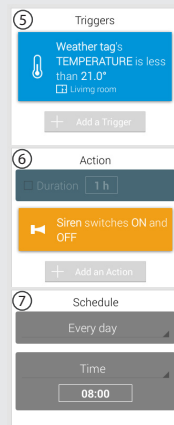

5 Triggers

Weather tag's TEMPERATURE is less than 21.0°
 Living room

+ Add a Trigger

6 Action

Duration 1 h

 Siren switches ON and OFF

+ Add an Action

7 Schedule

Every day

Time

08:00





ON Check weather

When Weather tag's TEMPERATURE is less than 21.0°
Siren switches ON and OFF
Every day Starts at 08:00





Programas

Para modificar un programa

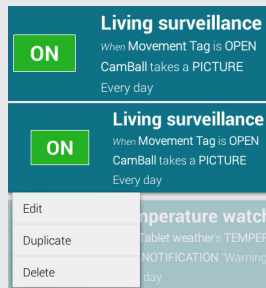
- 1 Abra la aplicación Archos Home .
 - 2 En la aplicación Archos Home, seleccione la pestaña Programas .
 - 3 Seleccione el programa que vaya a modificar.
- Aparecerán diversas opciones para el programa.
- 4 Seleccione "Edit" (Editar).
 - 5 Realice las modificaciones necesarias.
 - 6 Seleccione **SAVE** (Guardar)



Para activar o desactivar un programa

- 1 Abra la aplicación Archos Home .
 - 2 En la aplicación Archos Home, seleccione la pestaña Programas .
 - 3 Seleccione el programa que vaya a activar.
 - 4 Pulse **ON** para desactivar el programa **OFF**.
- 136 Pulse **OFF** para volver a activarlo **ON**.



Interacción con Archos Home

Sus accesorios están emparejados con la Home Tablet, de forma que podrá ver los datos de cada accesorio en la tableta.

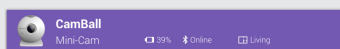

Los programas creados en la tableta crean interacciones entre esta última y los accesorios.

En la pestaña Habitaciones, cada recuadro de información corresponde a un accesorio determinado.



Pulse en un recuadro de información para mostrar el historial de datos.

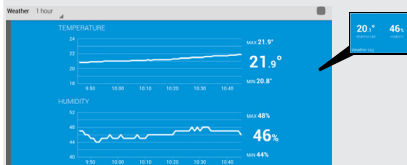

Su móvil le ayudará a manejar la tableta y los accesorios a distancia mediante la aplicación Archos Home.



ES



El Interfaz Android™

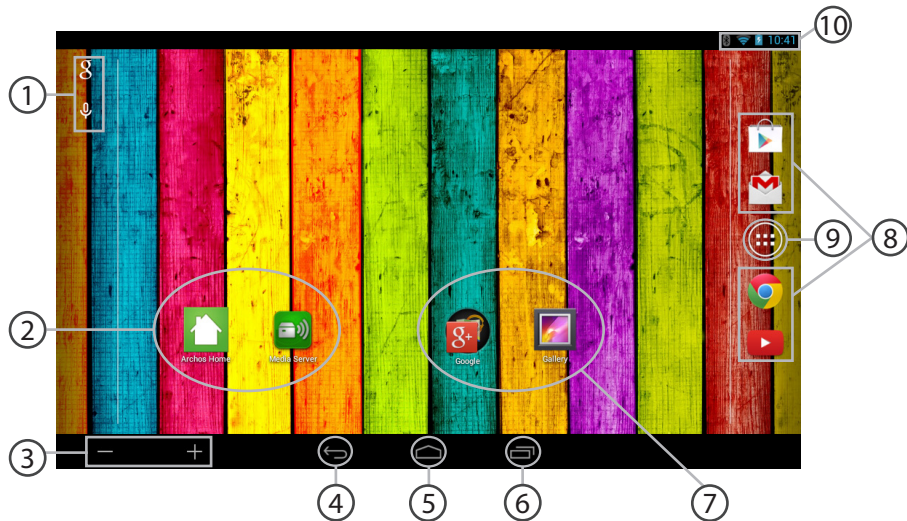



- ① **Google™ Search**
> Toque para búsqueda de texto o busque por voz .
- ② **Apps ARCHOS**
- ③ **Botones de volumen**
- ④ **"Volver"**
- ⑤ **"Inicio"**
- ⑥ **"Aplicaciones recientes"**
- ⑦ **Atajos de apps Google**
> Toque para iniciar una aplicación.
- ⑧ **Acceso directo permanente a aplicaciones Android™**
- ⑨ **"Todas las aplicaciones"**
> Toque este icono para mostrar todas las aplicaciones y widgets instalados en el ARCHOS. Todas las aplicaciones descargadas se encuentran aquí.
- ⑩ **Barra de estado**
> Muestra notificaciones y ajustes rápidos.



El Interfaz Android™

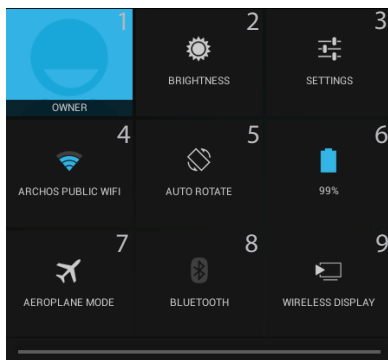

3:18 Los ajustes rápidos

- 1 Usuario actual⁽¹⁾
- 2 Para ajustar el brillo de la pantalla.
- 3 Para acceder a todos los ajustes.
- 4 Para activar/desactivar la conexión WiFi.
- 5 Para activar/desactivar la orientación automática de la pantalla al girar el ARCHOS.
- 6 Porcentaje de batería restante
- 7 Para activar/desactivar todas las conexiones inalámbricas, especialmente al volar.
- 8 Puede mostrar la interfaz Bluetooth
- 9 Para habilitar la visualización inalámbrica⁽²⁾

⁽¹⁾El nuevo soporte multiusuario para tabletas permite que distintos usuarios tengan sus propios espacios personalizables e independientes en un único dispositivo. Añada usuarios en Settings > Device [Ajustes > Dispositivo].

⁽²⁾Puede compartir películas, vídeos de YouTube y cualquier cosa que aparezca en pantalla en un televisor HD. Deberá conectar un adaptador de pantalla inalámbrico a su televisor habilitado HDMI para reflejar lo que aparece en pantalla de forma rápida y sencilla.



Aplicaciones recientes

Abre una lista de imágenes en miniatura de las aplicaciones con las que haya trabajado recientemente:

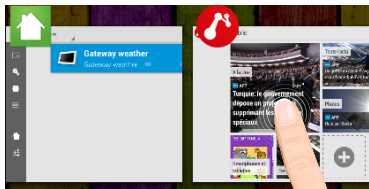

Tocar: para abrir una aplicación.

Mantener pulsado: para mostrar opciones

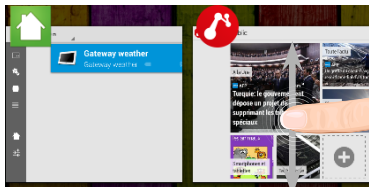

Mover el dedo arriba o abajo: para cerrar una aplicación.



Para familiarizarse con Android™

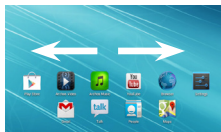

La pantalla de inicio ampliada:

Desplácese entre distintos paneles de la pantalla de inicio deslizando el dedo a la izquierda y a la derecha.

Desplazamiento de un elemento de la pantalla de inicio:

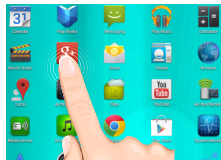

Mantenga el dedo sobre él hasta que aparezcan líneas de cuadrícula de posición; a continuación, deslícelo hasta la ubicación deseada y suelte el dedo.

Eliminación de un elemento de la pantalla de inicio:

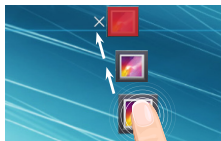

Mantenga el dedo sobre él, deslice el dedo hacia la parte superior de la pantalla y déjelo caer sobre el icono "Eliminar."

Desinstalación de un elemento:



En las pantallas Todas las aplicaciones, mantenga el dedo sobre él, deslice el dedo hacia la parte superior de la pantalla y déjelo caer sobre la papelera "Desinstalar".

Creación de carpetas de aplicaciones:



Deje caer un icono de aplicación sobre otro en una pantalla de inicio y los dos iconos se combinarán.

Widgets:



Toque el icono odas las aplicaciones en la pantalla de inicio. Toque "Widgets" en la parte superior de la pantalla. En la pantalla "Widgets" principal, puede desplazarse de un widget a otro de la misma manera que lo hace para los iconos de aplicaciones.

Cambio del fondo:

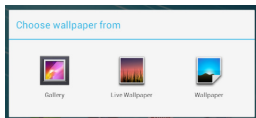

Mantenga el dedo en la pantalla en una ubicación vacía y, a continuación, elija en la lista.

Bloqueo de la pantalla táctil:

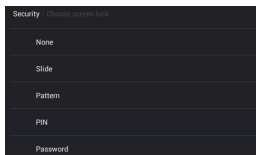

En el escritorio digital de ajustes rápidos de la barra de estado,

toque ajustes. Desplácese hacia abajo y toque "Seguridad" > "Bloqueo de la pantalla". Toque el tipo de bloqueo que desee utilizar. Tras definir aquí un bloqueo, aparecerá una pantalla de bloqueo cuando se active la pantalla, solicitando el patrón, PIN u otra clave especificada.



Solución de problemas

¿Qué puedo hacer si el Bluetooth no funciona correctamente?

Vaya a Ajustes > Conexiones inalámbricas y redes y seleccione Bluetooth. Seleccione Clic para reiniciar Bluetooth.

Bluetooth

Click to restart Bluetooth

¿Por qué no me puedo conectar a mi Home Tablet con el móvil?

Puede que esté conectado a una red protegida a través de un cortafuegos, lo que le impediría conectarse a su Home Tablet.

¿Por qué los accesorios no responden?

¿Están emparejados correctamente con su Home Tablet?

Compruebe que el Bluetooth de la tableta está activado.

Compruebe que las pilas no están gastadas. Si lo estuvieran, cámbielas por otras nuevas.

¿Por qué no puedo añadir más accesorios?

No puede emparejar más de 13 accesorios con su Home Tablet.

Si todavía no ha llegado a esa cantidad, verifique que el Bluetooth de la tableta está activado y que las pilas de los accesorios no están gastadas.

¿Cómo puedo restablecer mi dispositivo a los parámetros de fábrica?

1. Con el dispositivo apagado, enchufe el cable de alimentación al conector de alimentación.

2. Tan pronto como aparezca el logo de arranque de ARCHOS, pulse y mantenga pulsado el botón de restablecer durante 5 segundos con la punta de un clip.

Aparecerá la interfaz de recuperación de Android.

3. Seleccione una opción con el dedo.

4. Confirme con el botón ON/OFF.

- Seleccione "Borrar datos/restablecimiento a los parámetros de fábrica" y confirme para restaurar el dispositivo a su configuración original.
- Seleccione "Sí -- Borrar todos los datos de usuario" y confirme para eliminar todos los datos de usuario.
- Seleccione "Reiniciar sistema ahora" y confirme para reiniciar el dispositivo.



Sommario

Contenuto della confezione.....	146
Introduzione.....	147
ARCHOS Mini-Cam.....	148
ARCHOS Weather Tag.....	150
ARCHOS Movement Tag.....	152
Descrizione del tablet ARCHOS Smart Home.....	154
Procedura guidata.....	155
Connessione a una rete Wi-Fi.....	156
Interfaccia ARCHOS Home.....	158
ARCHOS HOME - Prima installazione.....	160
Interfaccia degli accessori.....	164
Gestione degli accessori.....	165
Connessione con il telefono cellulare.....	168
Programmi.....	170
Interazioni ARCHOS Home.....	173
L'interfaccia Android [™]	174
Introduzione ad Android [™]	178
Risoluzione dei problemi.....	180



Contenuto della confezione

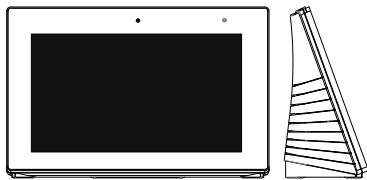

ARCHOS Smart Home Tablet



Mini Cam
X 2



Weather Tag
X 2



Movement Tag
X 2



Cavo USB



Caricatore



Guida dell'utente



Garanzia, note legali
e sulla sicurezza



Avvio

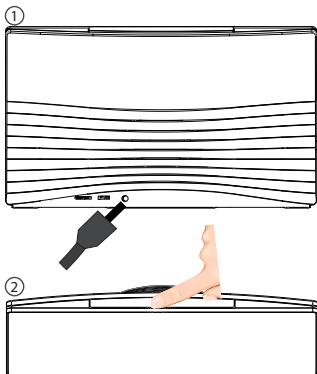

1. Collegare il cavo al connettore di alimentazione. Quando il cavo di alimentazione è collegato, la spia di alimentazione è di colore blu. Verrà avviato il caricamento del dispositivo.
2. Premere il pulsante ON/OFF [Acceso/Spento] per accendere il dispositivo.
 - È possibile utilizzare il dispositivo ARCHOS durante il caricamento.
 - Prima del primo utilizzo, lasciare che venga completato il caricamento del dispositivo.
 - Utilizzare solo il caricabatterie fornito.



Si consiglia di collegare il dispositivo al connettore di alimentazione ove possibile.

CONSIGLI:

Per ricevere un'assistenza più completa, registrare il prodotto.
Con un computer, andare su www.archos.com/register.



ARCHOS Mini Cam

Descrizione di Mini-Cam

- ① Pulsante di associazione
- ② Indicatore di associazione
- ③ Obiettivi della videocamera
- ④ Microfono
- ⑤ Adesivo

Installazione di Mini-Cam

La videocamera funziona con 3 batterie al litio CR2450.

1. Svitare la sfera della videocamera.
2. Rimuovere l'etichetta di isolamento "Rimuovere prima dell'uso".
3. Avvitare nuovamente la sfera.
4. Posizionare la videocamera sul supporto.

I magneti la manterranno stabile. È possibile puntare la videocamera in ogni direzione.

5. Rimuovere l'adesivo sul supporto per fissare il dispositivo al muro o al soffitto.

Quando si preme a lungo il pulsante di associazione (5 secondi)	Il LED lampeggia per 60 secondi	Il dispositivo si trova in modalità associazione e sta cercando di collegarsi a un tablet.
Quando si preme brevemente il pulsante di associazione	Il LED lampeggia per 10 secondi	Il dispositivo è già associato ma è disconnesso e cerca di connettersi.
	Il LED lampeggia 3 volte	Il dispositivo non è associato ed è disconnesso.
	Il LED rimane acceso per 5 secondi	Il dispositivo è associato e connesso.
	Il LED lampeggia rapidamente	È in corso un aggiornamento via etere.

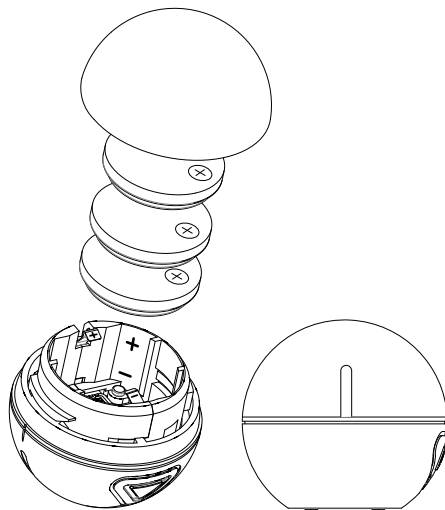
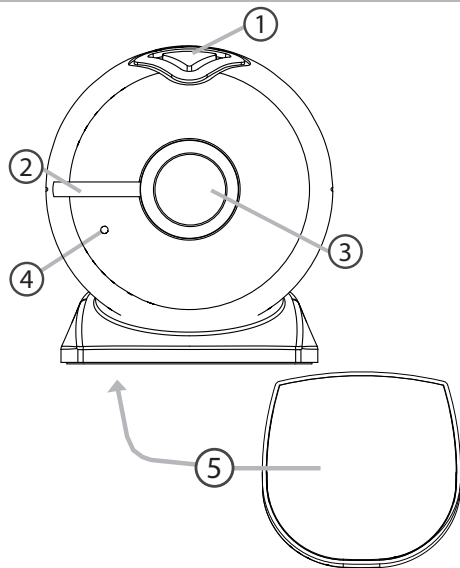

IT



ARCHOS Weather Tag

Descrizione di Weather Tag

- ① Indicatore di associazione
- ② Pulsante di associazione
- ③ Apertura
- ④ Adesivo

Installazione di Weather Tag

Weather Tag funziona con una batteria al litio CR2430.

1. Rimuovere l'involucro di gomma.
2. Separare la parte superiore dal contenitore posteriore.
3. Rimuovere l'etichetta di isolamento "Rimuovere prima dell'uso".
4. Riposizionare il contenitore posteriore e l'involucro di gomma.
5. Rimuovere l'adesivo sul contenitore posteriore per

Quando si preme a lungo il pulsante di associazione (5 secondi)	Il LED lampeggia per 60 secondi	Il dispositivo si trova in modalità associazione e sta cercando di collegarsi a un tablet.
Quando si preme brevemente il pulsante di associazione	Il LED lampeggia per 10 secondi	Il dispositivo è già associato ma è disconnesso e cerca di connettersi.
	Il LED lampeggia 3 volte	Il dispositivo non è associato ed è disconnesso.
	Il LED rimane acceso per 5 secondi	Il dispositivo è associato e connesso.
	Il LED lampeggia rapidamente	È in corso un aggiornamento via etere.

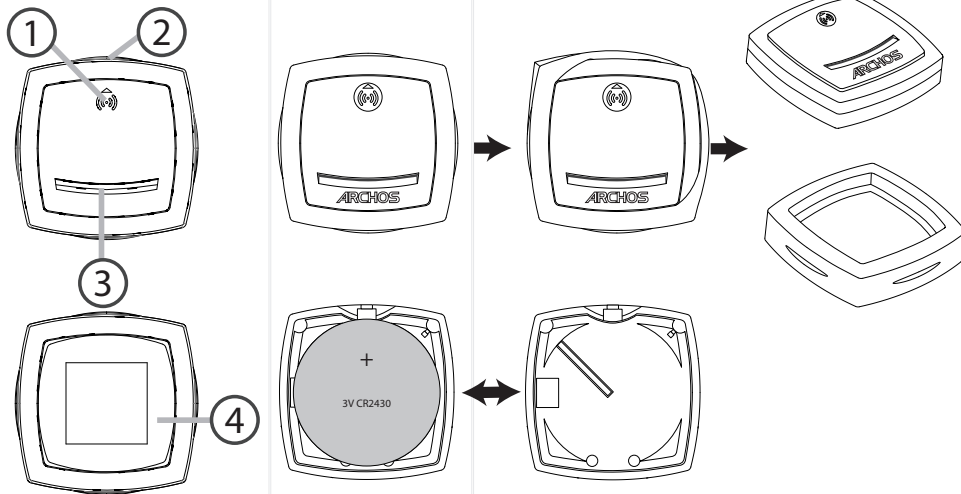



ARCHOS Movement Tag

Descrizione di Movement Tag

- ① Magnete
- ② Sensore del magnete
- ③ Indicatore del sensore del magnete
- ④ Pulsante di associazione
- ⑤ Indicatore di associazione
- ⑥ Involucro di gomma
- ⑦ Adesivo

Installazione di Movement Tag

Movement Tag funziona con una batteria al litio CR2430.

1. Rimuovere l'involucro di gomma del ricevitore magnetico.
2. Separare la parte superiore dal contenitore posteriore.
3. Rimuovere l'etichetta di isolamento "Rimuovere prima dell'uso".
4. Riposizionare il contenitore posteriore.
5. Rimuovere l'adesivo sul contenitore posteriore per fissare il dispositivo al muro.
6. Rimuovere l'adesivo sugli accessori per fissarli di fronte all'indicatore di posizione del magnete.

Quando si preme a lungo il pulsante di associazione (5 secondi)	Il LED lampeggia per 60 secondi	Il dispositivo si trova in modalità associazione e sta cercando di collegarsi a un tablet.
Quando si preme brevemente il pulsante di associazione	Il LED lampeggia per 10 secondi	Il dispositivo è già associato ma è disconnesso e cerca di connettersi.
	Il LED lampeggia 3 volte	Il dispositivo non è associato ed è disconnesso.
	Il LED rimane acceso per 5 secondi	Il dispositivo è associato e connesso.
	Il LED lampeggia rapidamente	È in corso un aggiornamento via etere.

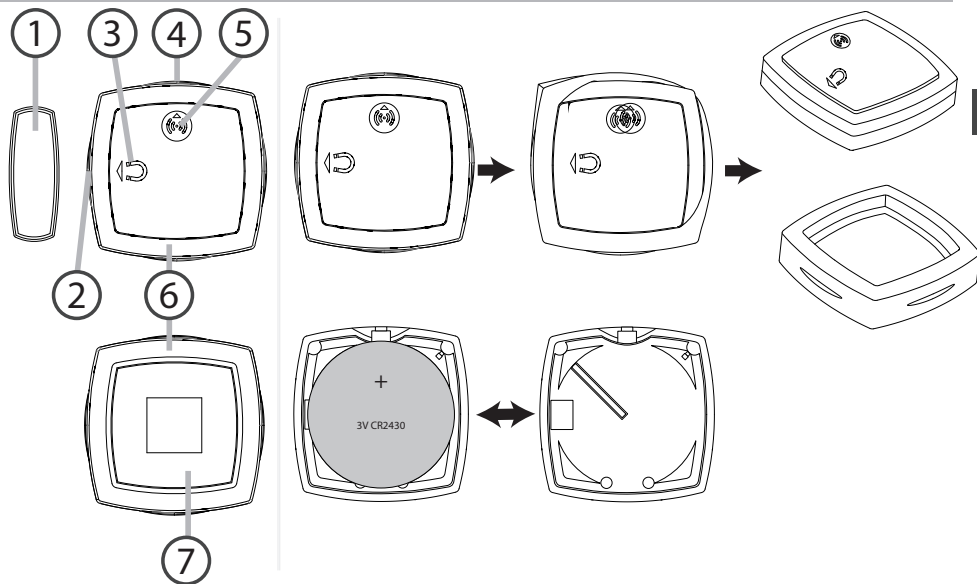



Descrizione del ARCHOS

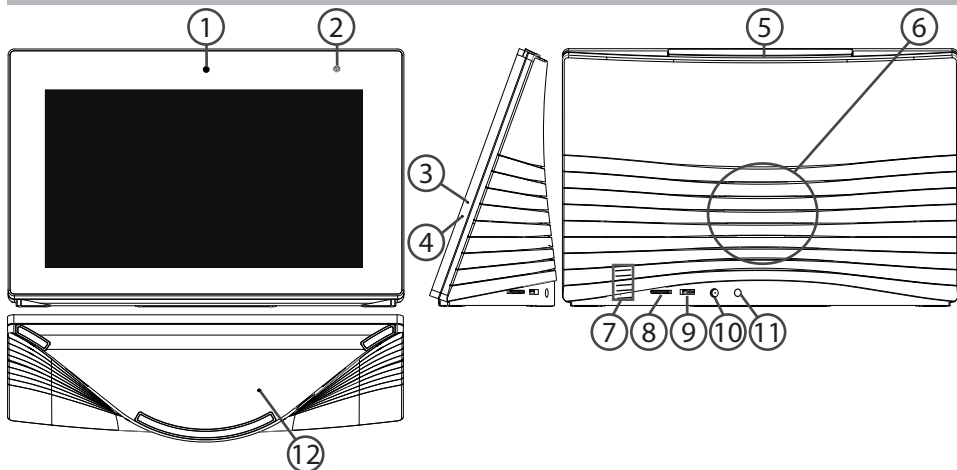

- | | | | |
|-------------------------|-----------------|--------------------------|----------------------------|
| ① Webcam | ④ Microfono | ⑦ Sensore di temperatura | ⑩ Connettore alimentazione |
| ② Sensore di luminosità | ⑤ Acceso/Spento | ⑧ Slot scheda micro SD | ⑪ Jack cuffie |
| ③ Indicatore di carica | ⑥ Altoparlante | ⑨ Porta micro USB | ⑫ Pulsante Reimposta |



Installazione guidata

La prima volta che si avvia ARCHOS, il wizard di installazione aiuterà ad installare il dispositivo :

- Lingua
- Connessione WiFi
- Impostazione account Google
- Il servizio di localizzazione
- Applicazioni di altri produttori

IT

CONSIGLI:

Definire i parametri del dispositivo nella zona della rete WiFi si utilizzano regolarmente.



Connessione a una rete wireless

ATTENZIONE: Accertarsi di essere in una zona coperta da WiFi.

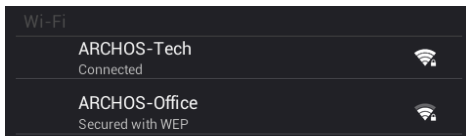

① Tocca e tieni premute le icone dell'orario e della batteria per visualizzare la barra di stato. Viene visualizzata una linea blu.

② Trascina la linea blu verso il basso per visualizzare il dashboard di stato.

③ Tocca "WiFi off" nel dashboard di stato. Verrà visualizzata la pagina WiFi.

④ Se la rete WiFi è disattivata, spostare il pulsante WiFi sulla posizione "ON".

⑤ Una volta attivata la rete WiFi, ARCHOS scansionerà le reti WiFi presenti. Selezionare il nome di rete a cui si desidera connettersi. Le reti private vengono visualizzate con un lucchetto e richiedono l'inserimento di una password.



Connessione rapida

È possibile connettersi alla rete Wi-Fi tramite WiFi Protected Setup [Impostazione protetta Wi-Fi].

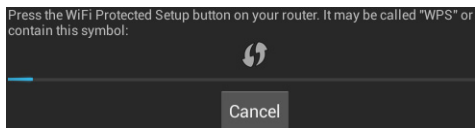

① Premere il pulsante WiFi Protected Setup [Impostazione protetta Wi-Fi]  in Settings > Wireless & networks [Impostazioni > Wireless e reti].

② Sul router Internet, premere il pulsante WiFi Protected Setup [Impostazione protetta Wi-Fi] denominato WPS o contenente il simbolo .

SUGGERIMENTI:

- Quando si immette una password Wi-Fi, si consiglia di selezionare l'opzione "Show password" [Mostra password] per visualizzare i caratteri che si stanno digitando. Per ottenere la password Wi-Fi corretta (o le impostazioni) per la rete, contattare il fornitore di rete Wi-Fi. ARCHOS tenterà di connettersi automaticamente alla rete a cui l'utente si è connesso in precedenza, purché il Wi-Fi sia acceso e l'utente si trovi nel raggio di quella rete.
- Per mantenere la connessione Wi-Fi mentre il dispositivo è in modalità sospensione, selezionare l'icona Menu nella pagina "WiFi" [Wi-Fi]. Quindi, selezionare Advanced > Keep Wi-Fi on during sleep > Always [Avanzate > Mantieni acceso Wi-Fi durante la sospensione > Sempre].

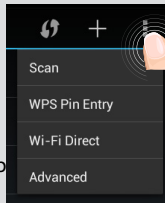



Interfaccia ARCHOS HOME

The screenshot displays the ARCHOS HOME interface. At the top, there is a 'Rooms' header with a home icon and window control icons (7 and 8). Below this, two tabs are visible: 'KITCHEN' and 'LIVING'. The 'LIVING' tab is selected and shows a camera feed of a room with a person at a desk (11:59), a weather widget (22.7° TEMPERATURE, 46% HUMIDITY), and a purple 'Idle' movement tag (UNKNOWN). Below the camera feed is another purple 'Closed' movement tag (UNKNOWN). A vertical sidebar on the left contains icons for home (1), settings (2), notifications (3), menu (4), mobile (5), and connectivity (6).



- ① **Scheda Rooms [Stanze]:**
visualizza le stanze create che corrispondono a quelle della propria casa.
- ② **Scheda Programs [Programmi]:**
visualizza i programmi creati senza gli oggetti associati.
- ③ **Scheda All accessories [Tutti gli accessori]:**
visualizza tutti gli accessori associati con il tablet Archos Smart Home.
- ④ **Scheda History [Cronologia]:**
visualizza la cronologia delle azioni dai diversi accessori.
- ⑤ **Scheda Connection [Connessione]:**
consente di connettere i dispositivi e gestire il tablet Home da lontano.
- ⑥ **Scheda General [Generale]:**
consente di aggiungere account di notifica e gestire le impostazioni.
- ⑦ **Stanza visualizzata:**
visualizza gli accessori situati nella stanza. Scorrere verso destra per visualizzare altre stanze.
- ⑧ **Barra dei menu:**
visualizza pulsanti di scelta rapida a seconda della scheda.



ARCHOS HOME - Prima installazione

La prima volta che si avvia l'applicazione, sarà necessario creare delle stanze. Le stanze create devono corrispondere alle stanze effettive in cui vengono situati gli accessori.

ROOMS [STANZE]

Creazione di una stanza	
1	Avviare l'applicazione Archos Home.
2	Selezionare Add a room [Aggiungi una stanza].
3	Digitare il nome della stanza e selezionare OK.
È possibile creare il numero di stanze che si desidera.	
4	Una volta terminato, selezionare Done [Fatto].

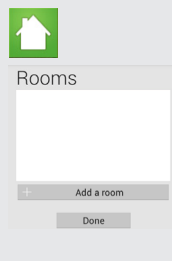



ASSOCIAZIONE

Una volta create le stanze, il passaggio successivo illustra come associare gli accessori al tablet.

Associazione di un accessorio

- 1 Controllare che il Bluetooth sia acceso (ON) nel tablet. In caso contrario, riavviarlo da Settings > Wireless & Networks [Impostazioni > Wireless e reti].
- 2 Selezionare l'accessorio desiderato.

Assicurarsi di aver rimosso l'etichetta di isolamento "Rimuovere prima dell'uso" nelle batterie.

- 3 Premere il pulsante di associazione dell'accessorio per 5 secondi.

L'indicatore di associazione inizia a lampeggiare.

- 4 Premere il pulsante Start [Avvia] sul tablet.

Il processo di associazione ha inizio.

Se l'associazione ha esito positivo, verrà visualizzato il messaggio indicato di seguito: **Successfully paired! [Associazione effettuata.] Premere OK per continuare.**

Successfully paired!
Press OK to continue

- 5 Selezionare OK.

È possibile collegare il dispositivo a una stanza esistente.



ARCHOS HOME - Prima installazione

Se il processo di associazione non avviene correttamente, verrà visualizzato il messaggio indicato di seguito:

Timeout

Press Cancel to continue

Il Bluetooth è acceso (ON) nel tablet?

- 1 Selezionare l'applicazione Settings [Impostazioni] sul tablet.
- 2 Dalla sezione Wireless & networks [Wireless e reti], riavviare Bluetooth.

L'indicatore di associazione dell'accessorio sta lampeggiando?

Per accenderlo, tenere premuto il pulsante di associazione dell'accessorio per 5 secondi.

Sarà necessario iniziare nuovamente l'associazione.

SUGGERIMENTI:

Quando si preme a lungo il pulsante di associazione (5 secondi)

Il LED lampeggia per 60 secondi: il dispositivo si trova in modalità associazione e sta cercando di collegarsi a un tablet.

Quando si preme brevemente il pulsante di associazione

Il LED lampeggia per 10 secondi: il dispositivo è già associato ma è disconnesso e cerca di connettersi.

Il LED lampeggia 3 volte: il dispositivo non è associato ed è disconnesso.

Il LED rimane acceso (ON) per 5 secondi: il dispositivo è associato e connesso.

Il LED lampeggia rapidamente: è in corso un aggiornamento via etere.



ASSEGNAZIONE DEL NOME

Dopo aver effettuato l'associazione, è necessario digitare un nome per l'accessorio.

Assegnazione di un nome all'accessorio

1 Digitare un nome per l'accessorio.

Si consiglia di scegliere un nome che consenta di identificare facilmente l'accessorio e la relativa posizione in casa.

2 Selezionare OK.

COLLEGAMENTO

Dopo aver assegnato un nome, è possibile selezionare le stanze in cui si desidera visualizzare il dispositivo.

Collegamento di un accessorio a una stanza

1 Controllare una o più stanze selezionate.

2 Selezionare Done [Fatto].

Una volta terminata l'installazione, gli accessori vengono visualizzati nella scheda All accessories [Tutti gli accessori].



Interfaccia degli accessori

Scheda All accessories [Tutti gli accessori]



The screenshot shows a mobile interface for managing accessories. At the top, there's a header 'Scheda All accessories [Tutti gli accessori]'. Below it, a sub-header 'All accessories' and 'Sort by room' are visible. A list of three accessories is shown: 'CamBall Mini-Cam' (39% battery, Online, Living), 'Movement Tag' (90% battery, Online, Living), and 'Weather Weather Tag' (92% battery, Online, Living). A legend on the right explains the icons: 1. Nome della sezione, 2. Tipo di ordinamento, 3. Qualità della connessione Bluetooth, 4. Aggiunta di ulteriori accessori, 5. - Livello della batteria, - Stato della connessione, - Stanza in cui è posizionato.

①	Nome della sezione
②	Tipo di ordinamento
③	Qualità della connessione Bluetooth
④	Aggiunta di ulteriori accessori
⑤	- Livello della batteria - Stato della connessione - Stanza in cui è posizionato



Gestione degli accessori

Creazione di più stanze



- 1 Nell'applicazione Archos Home, selezionare la sezione Rooms [Stanze] .
- 2 Nella sezione Rooms [Stanze], selezionare l'icona Rooms [Stanze]  nella barra dei menu.
- 3 Selezionare Add a room [Aggiungi una stanza] e digitare il nome della stanza.
Selezionare Done [Fatto] una volta terminato.

Rooms



IT



Modifica di una stanza già creata

- 1 Nell'applicazione Archos Home, selezionare la sezione Rooms [Stanze].
- 2 Nella sezione Rooms [Stanze], selezionare l'icona  nella barra dei menu.
- 3 Oltre al nome della stanza già esistente, selezionare  per modificare o eliminare la stanza.
- 4 Selezionare Done [Fatto] una volta terminato.



Gestione degli accessori

Associazione di più accessori

- 1 Nell'applicazione Archos Home, selezionare la sezione All accessories [Tutti gli accessori] .
- 2 Nella sezione All accessories [Tutti gli accessori], selezionare l'icona  nella barra dei menu.
- 3 Selezionare il tipo di accessorio che si desidera associare al tablet.

Assicurarsi di aver rimosso l'etichetta di isolamento "Rimuovere prima dell'uso" nelle batterie.

- 4 Premere il pulsante di associazione dell'accessorio per 5 secondi.

L'indicatore di associazione inizia a lampeggiare.

- 5 Premere il pulsante Start [Avvia] sul tablet.

Il processo di associazione ha inizio.

Selezionare OK se il processo viene effettuato correttamente o riavviare in caso contrario. Consultare la precedente sezione sugli accessori.

All accessories 

Accessories

Click on the accessory type you want to pair





Come rinominare un accessorio

1 Nell'applicazione Archos Home, selezionare la sezione All accessories [Tutti gli accessori]

2 Nella sezione All accessories [Tutti gli accessori], selezionare l'accessorio da rinominare.

Verrà visualizzato un elenco di opzioni.

3 Selezionare Rename [Rinomina], quindi OK.

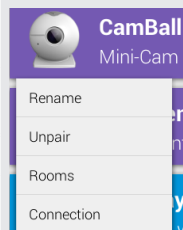

Collegamento di un accessorio a una stanza

1 Nell'applicazione Archos Home, selezionare la sezione All accessories [Tutti gli accessori]

2 Nella sezione All accessories [Tutti gli accessori], selezionare l'accessorio da rinominare.

Verrà visualizzato un elenco di opzioni.

3 Selezionare "Rooms" [Stanze].

4 Selezionare una o più stanze desiderate, quindi OK.

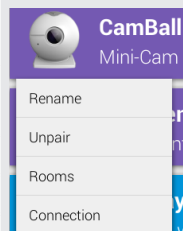



Connessione con il telefono cellulare

È possibile gestire il tablet Archos Smart Home tramite un telefono o un tablet quando ci si trova fuori casa.

Scaricamento dell'applicazione

- 1 Scaricare l'applicazione Archos Home da Play Store o da Appstore oppure rilevare il codice QR.
- 2 Dopo averla scaricata, avviare l'applicazione.

La prima volta che si avvia l'applicazione, si dispone di due opzioni per connettere il tablet Archos Smart Home.

Connessione sulla stessa rete Wi-Fi

- 1 Selezionare l'opzione **"if you are on the same home network than the Archos Home Gateway"** [Posizionati sulla stessa rete domestica di Archos Home Gateway].



Viene visualizzato il messaggio **"Looking for the Archos Home Gateways in your local network"** [Ricerca di gateway Archos Home nella rete locale]. Una volta rilevato sulla rete, verrà visualizzato il tablet Archos Home.

Premere per effettuare la connessione.



Viene inviata una richiesta di associazione al tablet Home.

Selezionare **Allow** [Consenti] sul tablet Home per autorizzare il dispositivo.

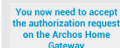



La connessione è in corso. Una volta connesso il dispositivo al tablet Home, sarà possibile gestirlo da qualsiasi luogo.

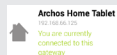

Connessione tramite una rete 3G o su una rete Wi-Fi diversa

- 1 Selezionare l'opzione **"If you are on a remote connection"** [Posizionati su una connessione remota].



Viene richiesto un codice per la connessione al tablet Home.



- 2 Nel tablet Home, avviare l'applicazione Archos Home, quindi selezionare la scheda Connection [Connessione].



- 3 Nella scheda Connection [Connessione], selezionare Authorize a device [Autorizza un dispositivo] nella barra dei menu.

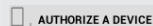

Viene fornita una chiave a 32 cifre che deve essere immessa sul dispositivo che tenta di connettersi al tablet Home.

- 4 Digitare la chiave a 32 cifre come codice richiesto.

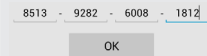

La connessione è in corso. Una volta connesso il dispositivo al tablet Home, sarà possibile gestirlo da lontano.

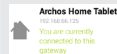



Programmi



Una volta associati gli accessori all'Home Tablet, sarà possibile creare dei programmi. Un programma è un'azione avviata da un trigger e pianificata per un periodo di tempo.

Interfaccia del programma



- ① Nome del programma
- ② Un trigger è un evento che crea una sequenza di azioni
- ③ Una durata imposta il limite temporale di un'azione
- ④ Un'azione è il risultato di un evento di trigger
- ⑤ Una pianificazione imposta il periodo di validità per la sequenza di azioni
- ⑥ Selezionare Save [Salva] per convalidare il programma e Cancel [Annulla] per arrestare la creazione.



Creazione di un programma

- 1 Avviare l'applicazione Archos Home .
- 2 Nell'applicazione Archos Home, selezionare la scheda Programs [Programmi] .
- 3 Selezionare  nella barra dei menu.

Viene visualizzata una finestra per creare un programma.

- 4 Digitare un nome.
- 5  : può trattarsi di una pianificazione, una rilevazione, un evento meteorologico.
- 6  : può trattarsi di una notifica, un'istantanea, un video. È possibile impostare una durata per l'azione
- 7 Definire un periodo di tempo in cui si verifica l'evento.
- 8 Selezionare **SAVE** [Salva].

Il programma viene creato ed è attivo.

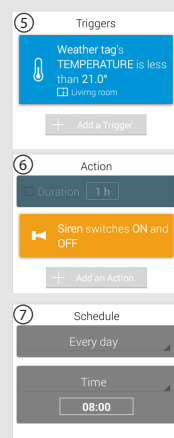

5 Triggers

Weather tag's
TEMPERATURE is less
than 21.0°
Living room

+ Add a Trigger

6 Action

Duration 1 h

Siren switches ON and
OFF

+ Add an Action

7 Schedule

Every day

Time

08:00

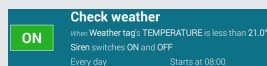

ON



Check weather

When Weather tag's TEMPERATURE is less than 21.0°
Siren switches ON and OFF
Every day Starts at 08:00



Programmi

Modifica di un programma

- 1 Avviare l'applicazione Archos Home .
 - 2 Nell'applicazione Archos Home, selezionare la scheda Programs [Programmi] .
 - 3 Selezionare il programma da modificare.
- Vengono visualizzate le opzioni per il programma.
- 4 Selezionare Edit [Modifica].
 - 5 Effettuare le modifiche necessarie.
 - 6 Selezionare **SAVE** [Salva].

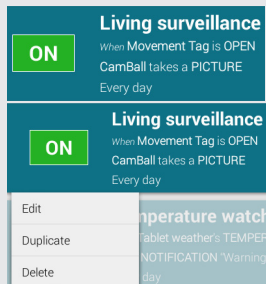

Living surveillance
When Movement Tag is OPEN
CamBall takes a PICTURE
Every day



ON

Living surveillance
When Movement Tag is OPEN
CamBall takes a PICTURE
Every day

Edit
Duplicate
Delete

temperature watch
table weather's TEMPER
NOTIFICATION 'Warning
day

Accensione o spegnimento (ON/OFF) di un programma

- 1 Avviare l'applicazione Archos Home .
 - 2 Nell'applicazione Archos Home, selezionare la scheda Programs [Programmi] .
 - 3 Selezionare il programma da avviare.
 - 4 Premere **ON** per spegnere il programma **OFF**.
- 172 Premere **OFF** per riaccenderlo di nuovo **ON**.

172



Interazioni ARCHOS Home

Gli accessori vengono associati con il tablet Home. Sul tablet vengono visualizzati i dati provenienti da ciascun accessorio.



I programmi creati sul tablet creano delle interazioni tra il tablet e gli accessori.
Nella scheda Rooms [Stanze], ciascun riquadro informativo corrisponde a un accessorio specifico.



Toccare un riquadro informativo per visualizzare i dati della cronologia.

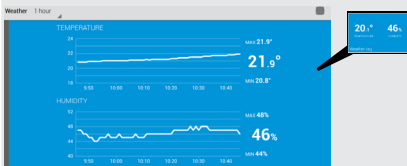

Il telefono consente di gestire il tablet e gli accessori da lontano tramite l'applicazione Archos Home.



IT



Interfaccia Android™

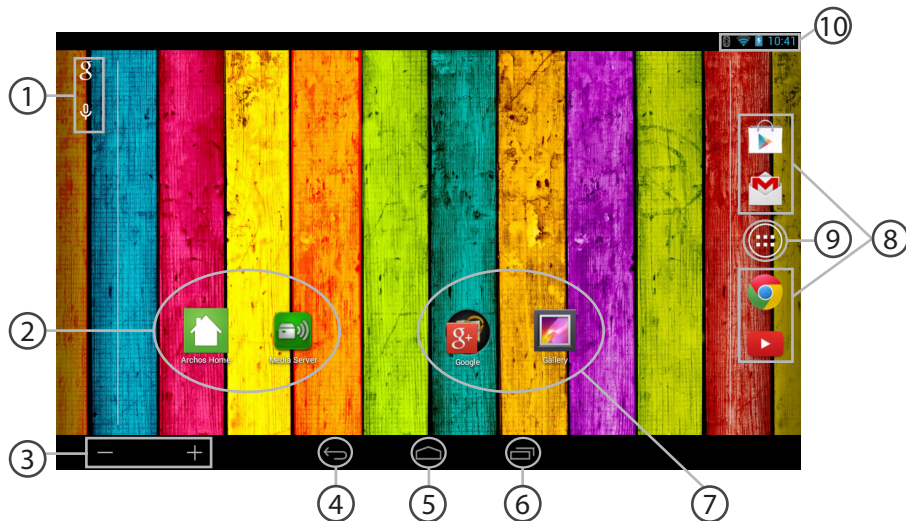



- ① **Google™ Search**
> Selezionare la ricerca per testo o per voce.
- ② **Applicazioni ARCHOS**
- ③ **Pulsanti del volume**
- ④ **“Indietro”**
- ⑤ **“Home”**
- ⑥ **“Applicazioni recenti”**
- ⑦ **Collegamenti applicazioni Google**
> Toccare per avviare un'applicazione.
- ⑧ **Icone permanenti di accesso rapido alle app Android™**
- ⑨ **“Tutte le applicazioni”**
> Selezionare questa icona per visualizzare tutte le applicazioni e i widget si accenderanno sul vostro ARCHOS. Tutte le applicazioni scaricate sono qui.
- ⑩ **Barra di stato**
> Che visualizza le notifiche e le impostazioni rapide.



Interfaccia Android™

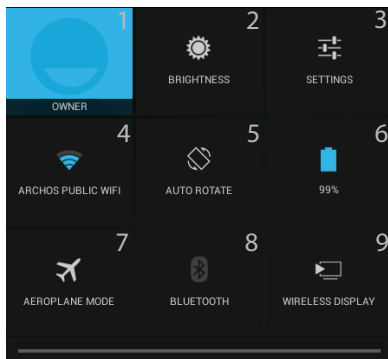

3:18 Impostazioni rapide

- 1 Utente corrente⁽¹⁾
- 2 Per regolare la luminosità dello schermo.
- 3 Per accedere a tutte le impostazioni.
- 4 Per attivare/disattivare la connessione WiFi.
- 5 Per attivare/disattivare l'orientamento automatico dello schermo mentre si ruota ARCHOS .
- 6 Percentuale di batteria rimasta
- 7 Per attivare/disattivare tutte le connessioni wireless, specialmente in volo.
- 8 È possibile visualizzare l'interfaccia Bluetooth
- 9 Per attivare il display wireless⁽²⁾

⁽¹⁾Il nuovo supporto multi-utente per i tablet permette a utenti diversi di avere ciascuno il proprio spazio distinto e personalizzabile su un singolo dispositivo. Puoi aggiungere utenti in Settings > Device [Impostazioni > Dispositivo].

⁽²⁾Puoi condividere film, filmati di YouTube e tutto ciò che vedi sullo schermo su un televisore HDTV. Per ritrasmettere il contenuto del tuo schermo in modo semplice e veloce, devi collegare un adattatore display wireless a una qualsiasi TV abilitata HDMI



Applicazioni recenti

Apri un elenco di immagini in miniatura delle applicazioni su cui si è recentemente lavorato:

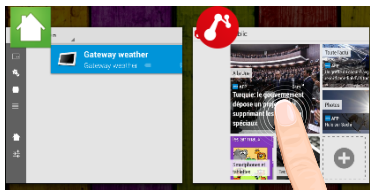

Tocca: per aprire una app.

Tieni premuto: visualizza le opzioni

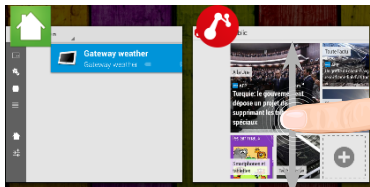

Scorri verso l'alto o il basso: chiudi un'app.



Conoscere Android™



Schermata iniziale estesa:

Navigare tra i vari pannelli della schermata iniziale sfiorando da sinistra o destra.

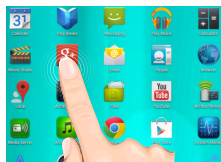

Spostare una voce della schermata iniziale:

Selezionare e tenere il dito su di essa fino a quando si visualizzano le linee della griglia di posizionamento, quindi scorrere nella posizione desiderata e togliere il dito.

Rimuovere una voce della schermata iniziale:

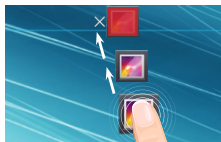

Selezionare e tenerla, scorrere il dito verso la parte superiore dello schermo e lasciare sull'icona "Rimuovi".

Disinstallare una voce:

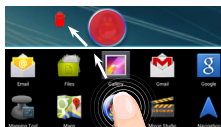

Dalle schermate Tutte le applicazioni, selezionare e tenere, scorrere il dito verso la parte superiore dello schermo e lasciare su "Cestino disinstalla".

Creare cartelle di applicazioni:



Lasciare un'icona di applicazione su un'altra icona della schermata iniziale e le due icone si combineranno.

Widget:



Selezionare l'icona "Tutte le applicazioni" della schermata iniziale. Toccare i "Widget" sulla parte superiore dello schermo. Dalla schermata principale Widget, è possibile spostare i widget proprio come si fa per le icone delle applicazioni.

Modificare lo sfondo:

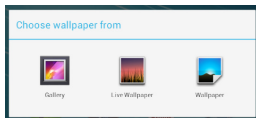

Tenere il dito sulla schermata su una posizione vuota, quindi selezionare dall'elenco.

Blocco del touchscreen:

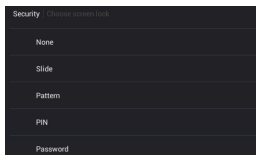

Dal pannello delle impostazioni rapide nella barra di stato, selezionare impostazioni. Scorrere e selezionare "Protezione" > "Bloccare il touchscreen". Selezionare il tipo di blocco che si desidera usare. Dopo aver impostato un blocco, un lucchetto viene visualizzato ogni volta che lo schermo si apre, richiedendo sequenza, PIN o altra chiave specificata.



Soluzione dei problemi

Cosa fare in caso di malfunzionamento del Bluetooth?

Accedere a Settings > Wireless & networks [Impostazioni > Wireless e reti], quindi selezionare Bluetooth. Selezionare Click to restart Bluetooth [Fare clic per riavviare il Bluetooth].

Bluetooth
Click to restart Bluetooth

Perché non è possibile effettuare la connessione al tablet Home dal telefono cellulare?

Si potrebbe essere connessi a una rete protetta che utilizza un firewall. In questo caso, viene impedita la connessione al tablet Home.

Perché gli accessori non rispondono?

Sono stati correttamente associati al tablet Home?

Controllare che il Bluetooth sia acceso (ON) nel tablet.

Controllare che le batterie non siano esaurite ed eventualmente, sostituirle.

Perché non è possibile aggiungere ulteriori accessori?

Non è possibile associare più di 13 accessori al tablet Home.

Se tale numero non è stato raggiunto, controllare che il Bluetooth sia acceso (ON) nel tablet e che le batterie degli accessori non siano scariche.

Come ripristinare il dispositivo alle impostazioni predefinite?

1. Quando il dispositivo è spento, collegare il cavo di alimentazione alla presa.
2. Non appena viene visualizzato il logo di avvio di ARCHOS, premere il pulsante di ripristino per 5 secondi con la punta di un fermaglio.
Verrà visualizzata l'interfaccia di ripristino di Android.
3. Selezionare un'opzione con il dito.
4. Convalidare con il pulsante ON/OFF [Acceso/Spento].
 - Selezionare "Wipe data/factory reset" [Cancella dati/ripristina impostazioni predefinite] e convalidare per ripristinare il dispositivo alle impostazioni predefinite.
 - Selezionare "Yes -- delete all user data" [Sì, elimina tutti i dati utente] e convalidare per rimuovere tutti i dati utente.
 - Selezionare "Reboot system now" [Riavvia il sistema ora] e confermare per riavviare il dispositivo.



Inhoudsopgave

Inhoud van de verpakking.....	182
Aan de slag.....	183
ARCHOS Mini-Cam.....	184
ARCHOS Weather Tag.....	186
ARCHOS Movement Tag.....	188
Beschrijving van de ARCHOS Smart Home Tablet.....	190
De Wizard gebruiken.....	191
Verbinding maken met een WiFi-netwerk.....	192
ARCHOS Home-interface.....	194
ARCHOS HOME - Eerste installatie.....	196
Accessoire-interface.....	200
Beheer van accessoires.....	201
Verbinding maken met uw mobiele telefoon.....	204
Programma's.....	206
Android™-interface.....	209
ARCHOS Home-interacties.....	210
Vertrouwd raken met Android™.....	214
Probleemoplossing.....	216
Raadpleeg voor meer informatie de veelgestelde vragen (FAQ's) op www.archos.com . Zorg ervoor dat u ze leest alvorens te overwegen het product te retourneren.	



Wat zit er in de doos?

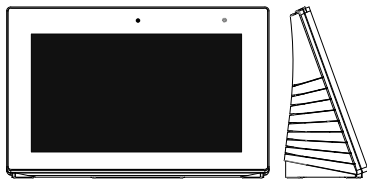

ARCHOS Smart Home Tablet



Mini Cam
X 2



Weather Tag
X 2



Movement Tag
X 2



USB-kabel



Lader



Gebruikershandleiding



Garantie, wettelijke
mededelingen en
veiligheidsvoorschrift



Aan de slag

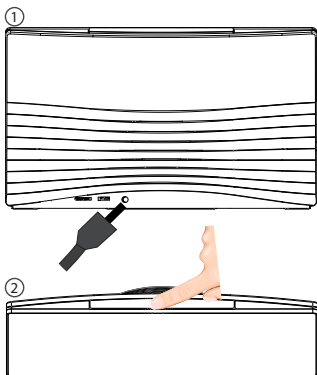

1. Connect your power cable into the power connector.
The Power indicator light is blue when the power cable is plugged in. The device will start charging.
2. Press the ON/OFF button to turn on the device.
 - You can use your ARCHOS whilst it charges.
 - Let your device charge completely the first time you use it.
 - Use only the supplied charger.



Your device should be connected to the power connector whenever possible.

TIPS:

Registreer uw product om de volledige service te ontvangen.
Als u een computer hebt, ga dan naar www.archos.com/register.



ARCHOS Mini Cam

Beschrijving van de Mini Cam

- 1 Pairing-knop
- 2 Pairing-lampje
- 3 Cameralens
- 4 Microfoon
- 5 Sticker

Installatie van de Mini Cam

De camera werkt op 3 Lithium cell CR 24 50-batterijen.

1. Schroef de camerabal los.
2. Verwijder het beschermlabel met de tekst "remove before use".
3. Schroef de bal er weer op.
4. Plaats de camera op de standaard.
De magneet houdt de camera op zijn plaats. U kunt de camera in iedere gewenste richting afstellen.
5. Verwijder de sticker op de standaard om het apparaat op een muur of plafond te plakken.

Als u de pairing-knop ingedrukt houdt (5 seconden)	De LED knippert gedurende 60 seconden	Het apparaat bevindt zich in de pairing-modus en probeert verbinding te maken met een tablet.
Als u kort op de pairing-knop drukt	De LED knippert gedurende 10 seconden	Het apparaat is al gekoppeld via pairing, maar de verbinding is verbroken. Het apparaat probeert een verbinding tot stand te brengen.
	De LED knippert 3 keer.	Het apparaat wordt ontkoppeld en de verbinding wordt verbroken.
	De LED brandt gedurende 5 seconden.	Het apparaat wordt gekoppeld (pairing) en de verbinding wordt tot stand gebracht.
	De LED knippert snel.	Er wordt een draadloze update uitgevoerd.

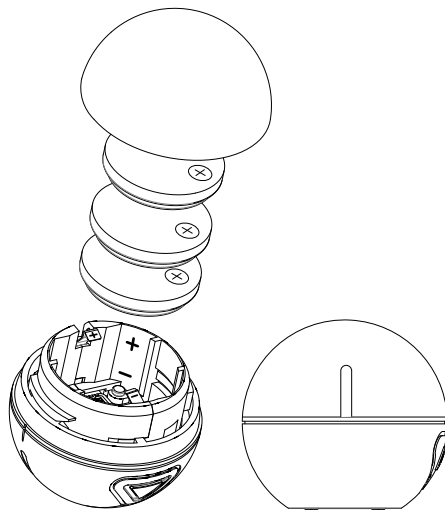
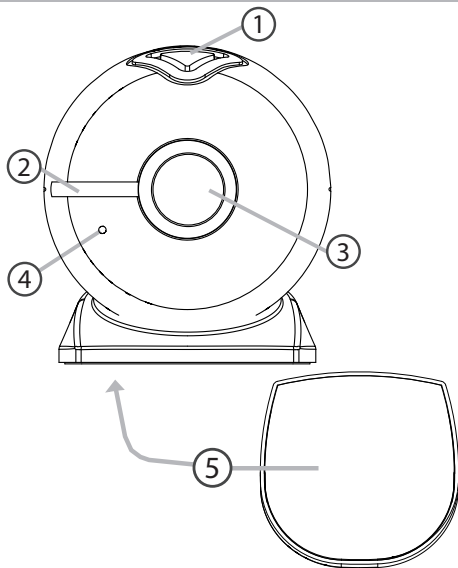

NL

en
de
ng



ARCHOS Weather Tag

Beschrijving van de Weather tag

- 1 Pairing-lampje
- 2 Pairing-knop
- 3 Openen
- 4 Sticker

Installatie van de Weather tag

De Weather Tag werkt op een Lithium cell CR 24 30-batterij.

1. Verwijder de rubberen lijst.
2. Maak de bovenkant los van de achterkant.
3. Verwijder het beschermlabel met de tekst "remove before use".
4. Plaats de achterkant en de rubberen lijst terug.
5. Verwijder de sticker op de achterkant om het apparaat op een muur te plakken.

Als u de pairing-knop ingedrukt houdt (5 seconden)	De LED knippert gedurende 60 seconden	Het apparaat bevindt zich in de pairing-modus en probeert verbinding te maken met een tablet.
Als u kort op de pairing-knop drukt	De LED knippert gedurende 10 seconden	Het apparaat is al gekoppeld via pairing, maar de verbinding is verbroken. Het apparaat probeert een verbinding tot stand te brengen.
	De LED knippert 3 keer.	Het apparaat wordt ontkoppeld en de verbinding wordt verbroken.
	De LED brandt gedurende 5 seconden.	Het apparaat wordt gekoppeld (pairing) en de verbinding wordt tot stand gebracht.
	De LED knippert snel.	Er wordt een draadloze update uitgevoerd.

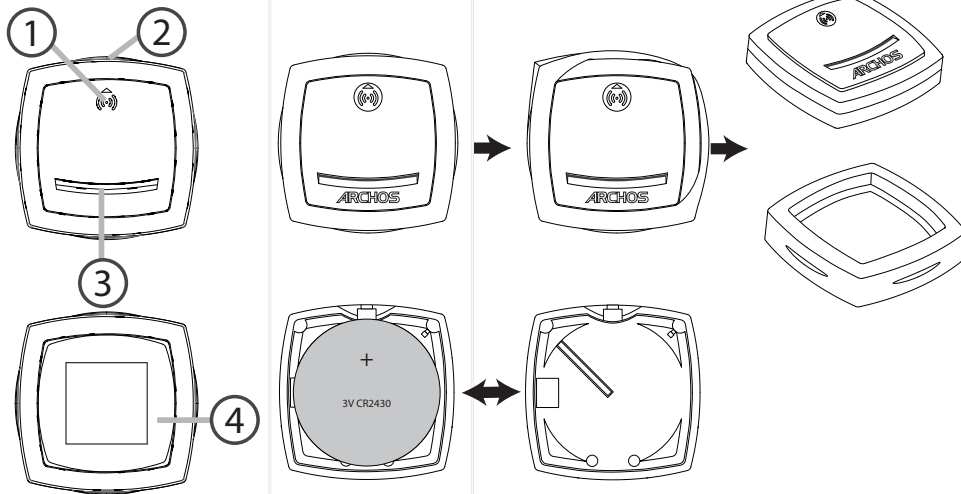



ARCHOS Movement Tag

Beschrijving van de Movement tag

- 1 Magneet
- 2 Magneetsensor
- 3 Magneetsensorknopje
- 4 Pairing-knopje
- 5 Pairing-knopje
- 6 Rubberen lijst
- 7 Sticker

Installatie van de Movement tag

De Movement Tag werkt met een Lithium cell CR 24 30-batterij.

1. Verwijder de rubberen lijst van de magneetontvanger.
2. Maak de bovenkant los van de achterkant.
3. Verwijder het beschermlabel met de tekst "remove before use".
4. Plaats de achterkant terug.
5. Verwijder de sticker op de achterkant om het apparaat op een muur te plakken.
6. Verwijder de sticker van de accessoires om deze tegenover het magneetnositieelamnie te plaatsen.

Als u de pairing-knop ingedrukt houdt (5 seconden)	De LED knippert gedurende 60 seconden	Het apparaat bevindt zich in de pairing-modus en probeert verbinding te maken met een tablet.
Als u kort op de pairing-knop drukt	De LED knippert gedurende 10 seconden	Het apparaat is al gekoppeld via pairing, maar de verbinding is verbroken. Het apparaat probeert een verbinding tot stand te brengen.
	De LED knippert 3 keer.	Het apparaat wordt ontkoppeld en de verbinding wordt verbroken.
	De LED brandt gedurende 5 seconden.	Het apparaat wordt gekoppeld (pairing) en de verbinding wordt tot stand gebracht.
	De LED knippert snel.	Er wordt een draadloze update uitgevoerd.

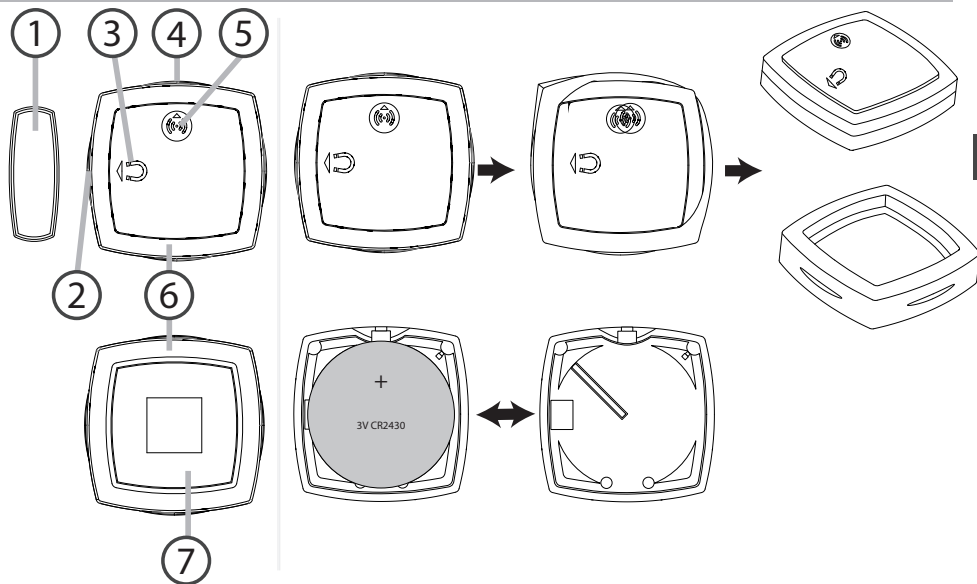



Beschrijving ARCHOS

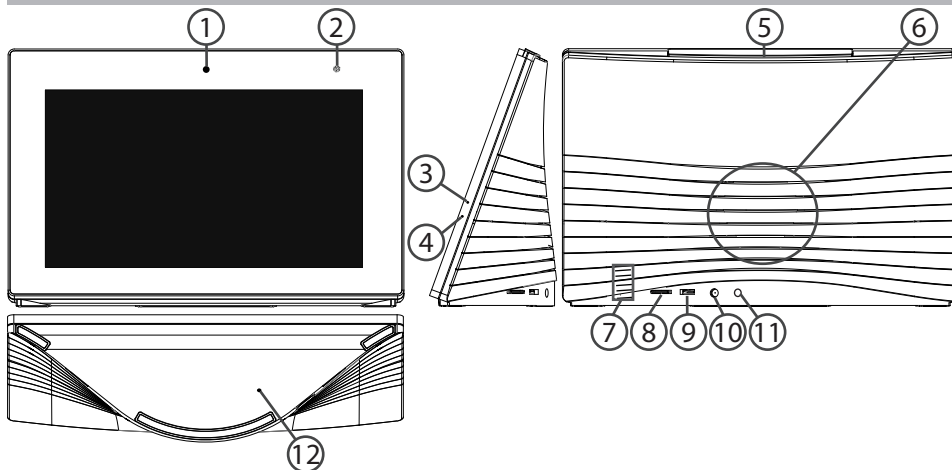

① Webcam

② Lichtsensor

③ Oplaadlampje

④ Microfoon

⑤ AAN/UIT-knop

⑥ Luidspreker

⑦ Temperatuursensor

⑧ Micro-SD-kaartsleuf

⑨ Micro-USB-poort

⑩ Voedingsaansluiting

⑪ Hoofdtelefoonaansluiting

⑫ Reset-knop



Installatiewizard

De eerste keer dat u uw ARCHOS inschakelt, zal de installatiewizard u helpen bij het instellen van uw apparaat :

- Taal
- WiFi-verbinding
- Google account instellen
- De locatieservice
- Toepassingen van derden

NL

TIPS:

Definieer de parameters van het apparaat op het gebied van het WiFi-netwerk zult u regelmatig gebruikt.



WiFi-netwerkverbinding

WAARSCHUWING: Zorg ervoor dat u zich in een WiFi-zone bevindt.

-  ① Houd uw vingers op de pictogrammen voor de tijd en de batterij om de statusbalk weer te geven. Er wordt een blauwe streep weergegeven.
-  ② Sleep de blauwe streep naar beneden om de statusinformatie weer te geven.
-  ③ Tik op "WiFi off" [WiFi uit] in de statusinformatie. De WiFi-pagina wordt weergegeven.
-  ④ Als de WiFi is uitgeschakeld, schuift u de WiFi-schakelaar in de stand "AAN".
-  ⑤ Zodra de WiFi is ingeschakeld, gaat de ARCHOS zoeken naar WiFi-netwerken die zich binnen het bereik bevinden. Tik op de naam van het netwerk waarmee u verbinding wilt maken. Privé-netwerken worden weergegeven met een slotje en vragen u om uw wachtwoord in te voeren.



Snel verbinding maken

U kunt verbinding maken met uw WiFi-netwerk via WiFi Protected Setup (Beveiligde WiFi-configuratie).

Press the WiFi Protected Setup button on your router. It may be called "WPS" or contain this symbol:

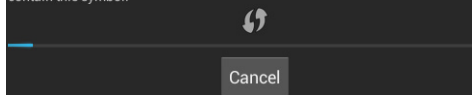

- 1 Druk op de knop WiFi Protected Setup (Beveiligde WiFi-configuratie)  bij Settings > Wireless & networks (Instellingen > Draadloos & Netwerken).
- 2 Druk op uw internetrouter op de knop voor beveiligde WiFi-configuratie. Deze knop wordt aangeduid met de letters WPS of met het symbool .

NL

TIPS:

- Tijdens het invoeren van een WiFi-wachtwoord kunt u het best "Show password" (Wachtwoord weergeven) selecteren zodat u de tekens tijdens het typen ziet. Neem voor het juiste wachtwoord (of voor de instellingen) van uw WiFi-netwerk contact op met uw WiFi-provider. Als WiFi is ingeschakeld en u zich binnen het bereik van een netwerk bevindt waarmee u eerder was verbonden dan probeert de ARCHOS automatisch opnieuw een verbinding tot stand te brengen.
- Om uw WiFi-verbinding ingeschakeld te houden als het apparaat in stand-by is, selecteert u het Menu-pictogram op de WiFi-pagina. Vervolgens selecteert u Advanced > Keep WiFi on during sleep > Always [Geavanceerd > WiFi aan in stand-by > Altijd]

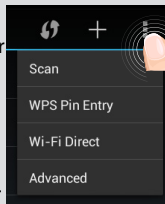



ARCHOS HOME-interface

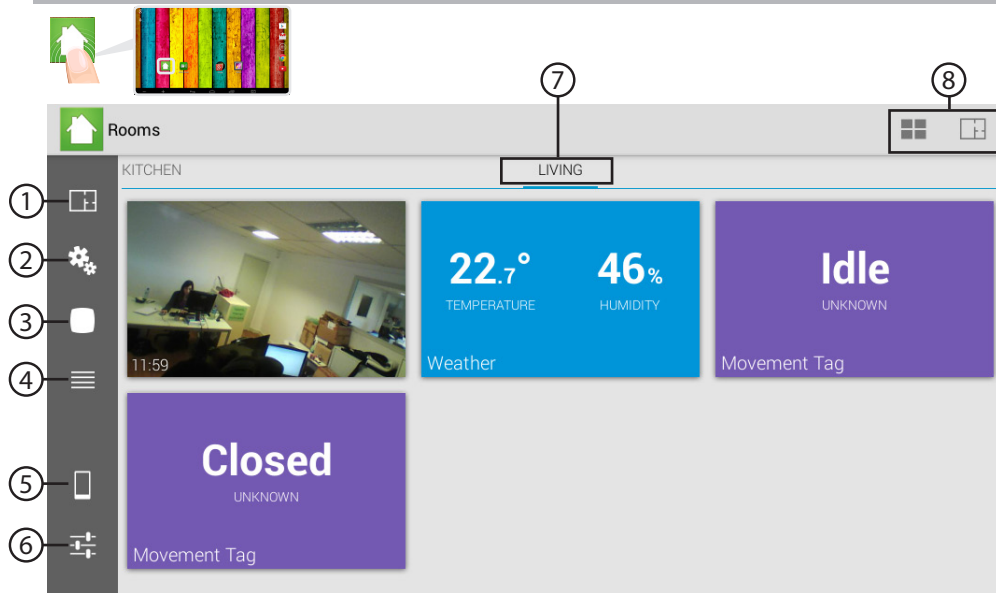



- ① **Tabblad Rooms (Kamers):**
weergave van de aangemaakte kamers die overeenkomen met de kamers in uw huis.
- ② **Tabblad Programs (Programma's):**
weergave van de programma's die zijn gemaakt met de gekoppelde accessoires.
- ③ **Tabblad All accessories (Alle accessoires):**
weergave van alle accessoires die zijn gekoppeld met de Archos Smart Home Tablet.
- ④ **Tabblad History (Geschiedenis):**
overzicht van uitgevoerde bewerkingen van de accessoires.
- ⑤ **Tabblad Connection (Verbindingen):**
om een verbinding tot stand te brengen met apparaten en voor beheer op afstand van de home tablet.
- ⑥ **Tabblad General (Algemeen):**
voor het toevoegen van notificatie-accounts en het beheren van instellingen.
- ⑦ **Room displayed (Weergegeven kamer):**
weergave van de accessoires in de betreffende kamer. Schuif naar rechts voor de weergave van andere kamers.
- ⑧ **Menubalk:**
weergave van contextmenuknoppen per tabblad.



ARCHOS HOME - Eerste installatie

Bij de eerste installatie van de app moet u kamers aanmaken. De kamers die u aanmaakt, moeten overeenkomen met de kamers in uw huis waar de accessoires zijn geplaatst.

KAMERS

Een kamer aanmaken	
1	Start de Archos Home app.
2	Kies Add a room (Kamer toevoegen).
3	Voer een naam in voor de kamer en kies OK.
U kunt zoveel kamers aanmaken als u wilt.	
4	Als u klaar bent, kiest u Done (Gereed).





PAIRING

Nadat u kamers heeft aangemaakt kunt u accessoires koppelen met uw tablet (pairing).

Een accessoire koppelen

- 1 Controleer of Bluetooth is ingeschakeld op de tablet. Zo niet, schakel deze dan in bij Settings > Wireless & Networks (Instellingen > Draadloos & Netwerken).
- 2 Kies het gewenste accessoire.

Controleer of het beschermlabel met de tekst "remove before use" voor de batterijen is verwijderd.

- 3 Druk 5 seconden lang op de pairing-knop van het accessoire.

Het paring-lampje begint te knipperen.

- 4 Druk op de Start-knop op de tablet.

Het pairing-proces wordt gestart.

Als de pairing is voltooid, wordt het volgende bericht weergegeven:

Successfully paired! (Pairing voltooid.) Press OK to continue (Druk op OK om verder te gaan)

Successfully paired!
Press OK to continue

- 5 Kies OK.

U wordt gevraagd of u het apparaat wilt koppelen met een bestaande kamer.



ARCHOS HOME - Eerste installatie

Als de pairing niet kon worden uitgevoerd, wordt het volgende bericht weergegeven:

Timeout
Press Cancel to continue

Is Bluetooth ingeschakeld op de tablet?

- 1 Kies de app Settings (Instellingen) op de tablet.
- 2 Bij Wireless & networks (Draadloos & Netwerken) schakelt u Bluetooth in.

Knippert het pairing-lampje van het accessoire?

Om dit in te schakelen houdt u de pairing-knop van het accessoire 5 seconden lang ingedrukt.

U moet de pairing opnieuw uitvoeren.

TIPS:

Als u de pairing-knop ingedrukt houdt (5 seconden).

De LED knippert gedurende 60 seconden. Het apparaat bevindt zich in de pairing-modus en probeert verbinding te maken met een tablet.

Als u kort op de pairing-knop drukt

De LED knippert gedurende 10 seconden. Het apparaat is al gekoppeld via pairing, maar de verbinding is verbroken. Het apparaat probeert een verbinding tot stand te brengen.

De LED knippert 3 keer. Het apparaat wordt ontkoppeld en de verbinding wordt verbroken.

De LED brandt gedurende 5 seconden. Het apparaat wordt gekoppeld (pairing) en de verbinding wordt tot stand gebracht.

De LED knippert snel: Er wordt een draadloze update uitgevoerd.



NAAM INVOEREN

Nadat de pairing is voltooid, moet u een naam invoeren voor het accessoire.

Naam invoeren voor een accessoire

1 Voer een naam in voor het accessoire.

Kies een naam die verwijst naar het accessoire en de plaats in uw huis.

2 Kies OK.

NL

KOPPELEN

Na de invoer van de naam kunt u de kamers kiezen die u op het apparaat wilt weergeven.

Een accessoire met een kamer koppelen

1 Selecteer de gekozen kamer(s).

2 Kies Done (Gereed).

Als u klaar bent met de installatie worden de accessoires weergegeven in het tabblad All accessories (Alle accessoires).



Accessoire-interface

Tabblad All accessories (Alle accessoires)

The screenshot shows the 'All accessories' tab with the following elements:

- 1. Tab title: All accessories
- 2. Sort by room dropdown menu
- 3. Bluetooth icon
- 4. Plus icon for adding more accessories
- 5. Battery level indicator (39%) for CamBall

①	Naam van rubriek.
②	Type sortering
③	Kwaliteit van Bluetooth-verbinding
④	Meer accessoires toevoegen
⑤	<ul style="list-style-type: none">- Batterijniveau- Verbindingsstatus- Kamer



Beheer van accessoires

Hoe kan ik meer kamers aanmaken?

- 1 In de Archos Home app kiest u de rubriek Rooms (Kamers) .
- 2 In de rubriek Rooms (Kamers) kiest u het pictogram  in de menubalk.
- 3 Kies Add a room (Kamer toevoegen) en voer de naam in van de kamer.
Kies Done (Gereed) als u klaar bent.

Rooms



NL

Hoe kan ik een bestaande kamer wijzigen?

- 1 In de Archos Home app kiest u de rubriek Rooms (Kamers) .
- 2 In de rubriek Rooms (Kamers) kiest u het pictogram  in de menubalk.
- 3 U kunt ook  kiezen om de kamer te wijzigen of te verwijderen.
- 4 Kies Done (Gereed) als u klaar bent.



Beheer van accessoires

Hoe kan ik nog meer accessoires koppelen via pairing?

- 1 In de app Archos Home kiest u de rubriek All accessories (Alle accessoires) 
- 2 Bij All accessories (Alle accessoires) kiest u het pictogram  in de menubalk.
- 3 Kies het type accessoire dat u met de tablet wilt koppelen via pairing.

Controleer of het beschermlabel met de tekst "remove before use" voor de batterijen is verwijderd.

- 4 Druk 5 seconden lang op de pairing-knop van het accessoire.

Het paring-lampje begint te knipperen.

- 5 Druk op de Start-knop op de tablet.

Het pairing-proces wordt gestart.

Kies OK als de pairing is voltooid of herhaal het proces indien nodig. Zie de vorige accessoirerubriek.

All accessories 

Accessories

Click on the accessory type you want to pair





Hoe kan ik de naam van een accessoire wijzigen?

- 1 In de app Archos Home kiest u de rubriek All accessories (Alle accessoires)
- 2 Bij All accessories (Alle accessoires) kiest u het accessoire  waarvan u de naam wilt wijzigen.

Er wordt een lijst met opties weergegeven.

- 3 Kies Rename (Naam wijzigen) en dan OK.

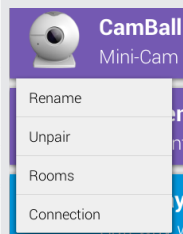

NL

Hoe kan ik een accessoire met een kamer koppelen?

- 1 In de app Archos Home kiest u de rubriek All accessories (Alle accessoires)
- 2 Bij All accessories (Alle accessoires) kiest u het accessoire  waarvan u de naam wilt wijzigen.

Er wordt een lijst met opties weergegeven.

- 3 Kies Rooms (Kamers).
- 4 Kies de gewenste kamer(s) en dan OK.

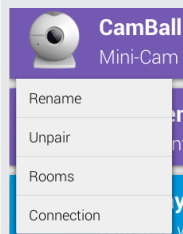



Verbinding maken met uw mobiele telefoon

Als u niet thuis bent, kunt u uw Archos Smart Home Tablet bedienen met een mobiele telefoon of tablet.

De app downloaden

- 1 Download de Archos Home app in de Play Store of Appstore of scan de QR-code.
- 2 Na het downloaden start u de applicatie.

De eerste keer dat u de applicatie start, heeft u twee opties om verbinding te maken met de Archos Smart Home Tablet.

Verbinding maken via hetzelfde WiFi-netwerk

- 1 Kies de optie **“if you are on the same home network than the Archos Home Gateway”** (als u op hetzelfde thuisnetwerk bent als de .Archos Home Gateway).



Het bericht **“Looking for the Archos Home Gateways in your local network”** (Bezig met zoeken naar de Archos Home Gateways in uw lokale netwerk) wordt weergegeven. Zodra een Archos Home Tablet in uw netwerk is gevonden, wordt hij weergegeven.

Druk om verbinding te maken.



Er wordt een pairing-verzoek verzonden naar de Home Tablet.

Kies **Allow** (Toestaan) op de Home Tablet om het apparaat toe te staan.





De verbinding wordt tot stand gebracht. Als uw apparaat is verbonden met de Home Tablet dan kunt u uw home tablet overal beheeren.

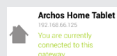

Verbinding maken via een 3G-netwerk of een ander WiFi-netwerk

- 1 Kies de optie **"If you are on a remote connection"** (als u zich in een ander netwerk bevindt).



Er wordt een code gevraagd om verbinding te maken met de Home Tablet.

- 2 Op de Home Tablet start u de Archos Home app en kiest u het Tabblad Connection (Verbindingen).



- 3 In het tabblad Connection (Verbindingen) kiest u **Authorize a device** (Een apparaat toestaan) in de menubalk.

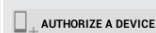

Er wordt een code van 32 tekens gegeven. U moet de code invoeren op het apparaat dat verbinding probeert te maken met de Home Tablet.

- 4 Voer de code van 32 tekens in.

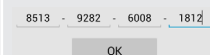

De verbinding wordt tot stand gebracht. Als uw apparaat is verbonden met de Home Tablet dan kunt u uw home tablet op afstand beheeren.

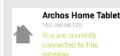

NL

205



Programma's

Wanneer uw accessoires via pairing zijn gekoppeld met uw Home Tablet kunt u programma's maken.

Een programma is een reeks bewerkingen die in gang worden gezet door een trigger. Een programma wordt voor een bepaalde periode geprogrammeerd.

Programma-interface

- ① Naam van het programma
- ② Een trigger is een gebeurtenis die een reeks bewerkingen in gang zet.
- ③ Duration (Duur) is de tijdsduur van een bewerking.
- ④ Action (Bewerking) is het resultaat van een trigger-gebeurtenis.
- ⑤ Schedule (Periode) is de geldigheidsduur van een reeks bewerkingen.
- ⑥ Met Save (Opslaan) kunt u het programma bevestigen en met Cancel (Annuleren) kunt u de bewerking stoppen.



Programma maken

- 1 Start de Archos Home app .
 - 2 In de Archos Home app kiest u het tabblad Programs (Programma's) .
 - 3 Kies  in de menubalk.
- Er wordt een venster weergegeven om een programma te maken.
- 4 Voer een naam in.
 - 5  : dit kan een periode, een detectie, een weersgebeurtenis zijn.
 - 6  : dit kan een melding, een snapshot, een video zijn. U kunt een tijdsduur instellen voor een bewerking.
 - 7 Voer de periode in waarin de gebeurtenis plaatsvindt.
 - 8 Kies **SAVE (OPSLAAN)**.

Het programma is aangemaakt en is actief.

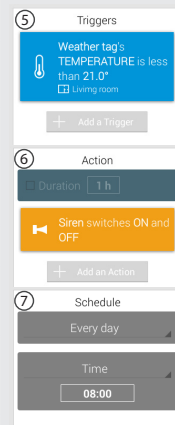

5 Triggers

Weather tag's TEMPERATURE is less than 21.0°
 Living room

+ Add a Trigger

6 Action

Duration: 1 h

Siren switches ON and OFF

+ Add an Action

7 Schedule

Every day

Time

08:00



ON Check weather

when Weather tag's TEMPERATURE is less than 21.0°
Siren switches ON and OFF
Every day Starts at 08:00



Programma's

Programma wijzigen

- 1 Start de Archos Home app .
 - 2 In de Archos Home app kiest u het tabblad Programs (Programma's) .
 - 3 Selecteer het programma dat u wilt wijzigen.
- Er worden opties weergegeven voor het programma.
- 4 Kies Edit (Bewerken).
 - 5 Breng de gewenste wijzigingen aan.
 - 6 Kies **SAVE (OPSLAAN)**.

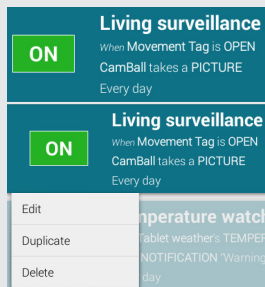

Living surveillance
When Movement Tag is OPEN
CamBall takes a PICTURE
Every day

ON



Living surveillance
When Movement Tag is OPEN
CamBall takes a PICTURE
Every day

ON

Edit
Duplicate
Delete

Temperature watch
Tablet weather's TEMPER
NOTIFICATION Warning
day

Een programma in- of uitschakelen

- 1 Start de Archos Home app .
 - 2 In de Archos Home app kiest u het tabblad Programs (Programma's) .
 - 3 Selecteer het programma dat u wilt inschakelen.
 - 4 Druk op **ON** om het programma uit te schakelen **OFF**.
- Druk op **OFF** om het weer in te schakelen **ON**.



ARCHOS Home-interacties

Uw accessoires zijn gekoppeld met uw Home Tablet. De gegevens van ieder accessoire worden weergegeven op de tablet.

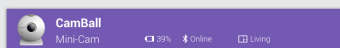

Programma's die op uw tablet zijn gemaakt, brengen interacties tussen uw tablet en accessoires tot stand. In het tabblad Rooms (Kamers) komt ieder informatieblokje overeen met een specifiek accessoire.



NL

Tik op een informatieblokje voor de weergave van een historisch overzicht.

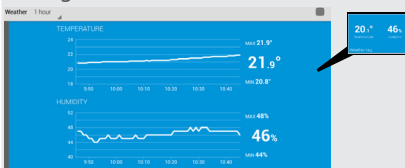

Via uw telefoon en de app Archos Home kunt u uw tablet en accessoires op afstand beheeren.





De Android™-Interface

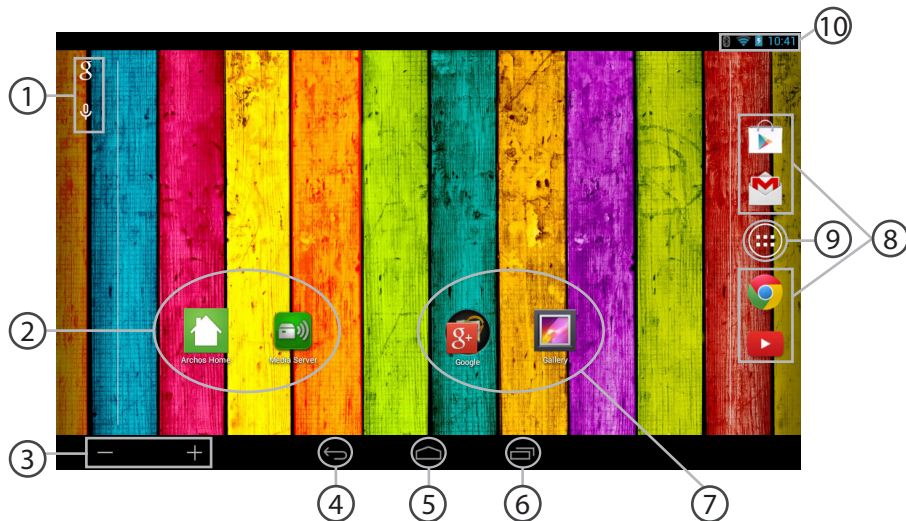



- ① **Google™ Search**
> Tik voor zoeken op tekst of zoeken met stem.
- ② **ARCHOS apps**
- ③ **Volume knoppen**
- ④ **"Terug"**
- ⑤ **"Startpagina"**
- ⑥ **"Recente apps"**
- ⑦ **Snelkoppelingen van Google-apps**
> Tik op een app om te starten.
- ⑧ **Snelkoppelingen van permanente Android™-apps**
- ⑨ **"Knop Alle" Apps**
> Tik op dit pictogram om alle applicaties en widgets weer te geven die op uw ARCHOS zijn geïnstalleerd. Al uw gedownloade applicaties bevinden zich hier.
- ⑩ **Statusbalk**
> Geeft meldingen en snelinstellingen weer.



De Android™-Interface

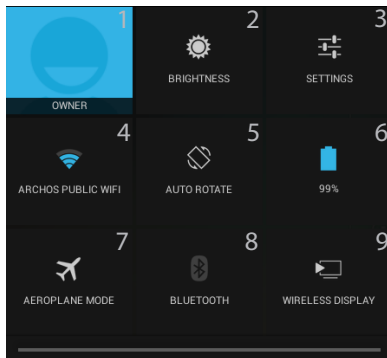

3:18 De Snelinstellingen

- 1 Huidige gebruiker⁽¹⁾
- 2 Om de helderheid van het scherm aan te passen.
- 3 Om al uw instellingen te openen.
- 4 Om uw WiFi-verbinding aan/uit te zetten.
- 5 Om de automatische oriëntatie van het scherm te activeren/deactiveren als u uw ARCHOS draait.
- 6 Percentage batterijlading
- 7 Om alle draadloze verbindingen te activeren/deactiveren, in het bijzonder tijdens het vliegen.
- 8 U kunt Bluetooth-interface weer te geven
- 9 Per attivare il display wireless⁽²⁾

⁽¹⁾Nieuwe tabletondersteuning voor meerdere gebruikers waarbij iedere gebruiker zijn eigen ruimte op de tablet kan maken en aanpassen. Voeg gebruikers toe bij Settings > Device [Instellingen > Apparaat]

⁽²⁾Puoi condividere film, filmati di YouTube e tutto ciò che vedi sullo schermo su un televisore HDTV. Per ritrasmettere il contenuto del tuo schermo in modo semplice e veloce, devi collegare un adattatore display wireless a una qualsiasi TV abilitata HDMI.



Recente apps

Hiermee opent u een lijst van miniatuurafbeeldingen van apps waarmee u onlangs hebt gewerkt:

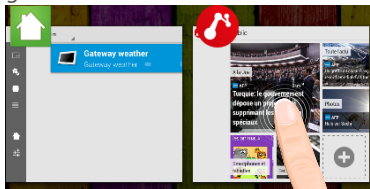

Aanraken: een app openen.

Vasthouden: opties weergeven

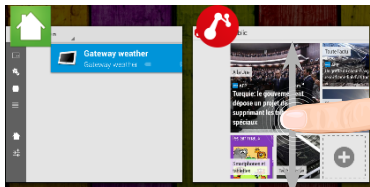

Op en neer vegen: een app sluiten.

NL



Vertrouwd raken met Android™



Het uitgebreide startscherm:

Navigeren tussen de verschillende startschermpanelen door er van links en rechts overheen te vegen.

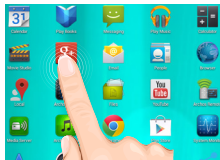

Het verplaatsen van een item op het startscherm:

Tik en houd uw vinger op zijn plaats tot de positioneringsrasterlijnen verschijnen, dan schuift u deze naar de gewenste locatie en laat uw vinger vervolgens weer los.

Het verwijderen van een item op het startscherm:

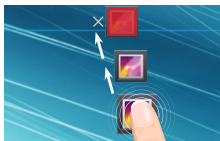

Tik en houd uw vinger op het item en schuif dit vervolgens naar de bovenkant van het scherm en zet het op het pictogram "Verwijderen".

Verwijderen van een item:

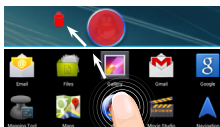

Tik in de schermen Alle apps op het item en houd uw vinger daar, schuif vervolgens uw vinger in de richting van de bovenkant van het scherm en plaats het item op de prullenbak "Verwijderen".

Het aanmaken van applicatiemappen:



Plaats op een startscherm het ene app-pictogram op het andere, en de twee pictogrammen worden gecombineerd.

Widgets:



Tik in uw startscherm op het pictogram "Alle apps". Tik op "Widgets" aan de bovenkant van het scherm. Vanaf het Widgets-hoofdscherm kunt u widgets op dezelfde manier verplaatsen als app-pictogrammen.

Uw wallpaper wijzigen:

Houd uw vinger op het scherm op een lege plek en maak

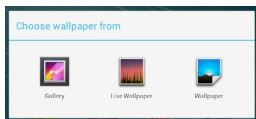

vervolgens een selectie uit de lijst.

Het vergrendelen van het aanraakscherm:

Tik vanuit het snelinstellingen-dashboard op instellingen. Scroll

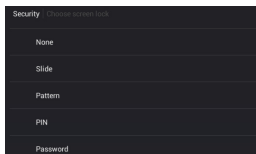

naar beneden en tik op veiligheid. Tik op "Scherm vergrendelen". Tik op het type slot dat u wilt gebruiken. Nadat u hier een slot hebt ingesteld, wordt er een vergrendelscherm weergegeven wanneer uw scherm 'wakker' wordt, dat om het patroon, de PIN of een andere specifieke toets vraagt.



Problemen oplossen

Wat moet ik doen bij een Bluetooth-storing?

Ga naar Settings > Wireless & networks (Instellingen > Draadloos & Netwerken) en kies Bluetooth. Kies Click to restart Bluetooth (Klik om Bluetooth opnieuw te starten).

Bluetooth

Click to restart Bluetooth

Waarom kan ik geen verbinding maken tussen mijn Home Tablet en mijn mobiele telefoon?

Mogelijk bent u verbonden met een beveiligd netwerk dat firewalls gebruikt. In dat geval kunt u geen verbinding maken met uw Home Tablet.

Waarom reageren mijn accessoires niet?

Zijn ze gekoppeld (via pairing) met uw Home Tablet?

Controleer of Bluetooth is ingeschakeld op de tablet.

Controleer of de batterijen niet leeg zijn. Vervang de batterijen als ze leeg zijn.

Waarom kan ik niet nog meer accessoires toevoegen?

U kunt maximaal 13 accessoires koppelen met uw Home Tablet.

Als u dit maximum nog niet heeft bereikt, controleer dan of Bluetooth is ingeschakeld op de tablet of controleer of de batterijen niet leeg zijn.

Hoe kan ik de standaardinstellingen van mijn apparaat herstellen?

1. Als het apparaat is uitgeschakeld, sluit u de voedingskabel aan op de voedingsaansluiting.
2. Zodra het ARCHOS bootlogo wordt weergegeven, drukt u 5 seconden lang op de reset-knop met het uiteinde van een paperclip.

De Android-herstelinterface wordt weergegeven.

3. Kies een optie met uw vinger.
4. Bevestig uw keuze met de AAN/UIT-knop.
 - Kies "Wipe data/factory reset" (Gegevens wissen/fabrieksreset) en bevestig uw keuze om de standaardinstellingen van uw apparaat te herstellen.
 - Kies "Yes -- delete all user data" (Ja, alle gebruikersgegevens wissen) en bevestig uw keuze om alle door de gebruiker ingestelde gegevens te wissen.
 - Kies "Reboot system now" (Nu opnieuw opstarten) en bevestig uw keuze om het apparaat opnieuw op te starten.



Índice

Conteúdos do Pacote.....	218
Início.....	219
ARCHOS Mini-Cam (minicâmara).....	220
ARCHOS Weather Tag (sensor de ambiente).....	222
ARCHOS Movement Tag (sensor de movimento).....	224
Descrição do ARCHOS Smart Home Tablet.....	226
O assistente.....	227
Ligar a uma rede Wi-Fi.....	228
A interface do ARCHOS Home.....	230
ARCHOS HOME: instalação inicial.....	232
A interface dos acessórios.....	236
Gestão dos acessórios.....	237
Ligação a dispositivos móveis.....	240
Programas.....	242
As interações do ARCHOS Home.....	245
A interface Android™.....	246
Familiarização com o Android™.....	250
Resolução de problemas.....	252

Para obter mais informações, consulte as Perguntas frequentes em www.archos.com. Certifique-se de que os consulta antes de colocar a hipótese de devolver qualquer produto.



Conteúdo da embalagem

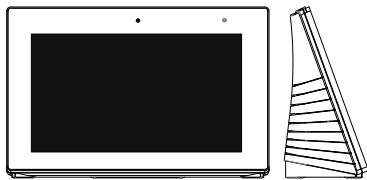

ARCHOS Smart Home Tablet



Mini Cam
X 2



Weather Tag
X 2



Movement Tag
X 2



Cabo USB



Carregador



Guia do usuário



Garantia, avisos legais e
de segurança



Início

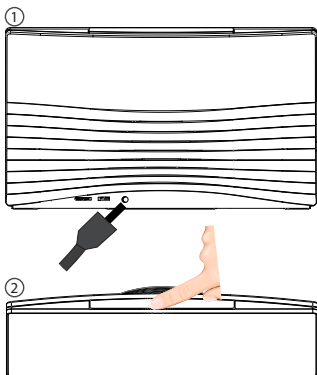

1. Ligue o cabo de alimentação à ficha de alimentação. A luz do indicador de energia ficará azul, quando o cabo de alimentação está ligado. O dispositivo começará a receber carga.
2. Prima o botão Ligar/Desligar para ligar o dispositivo.
 - Pode utilizar o ARCHOS enquanto este recebe carga.
 - Deixe o seu dispositivo carregar completamente antes da primeira utilização.
 - Utilize apenas o transformador fornecido.

 **Deve manter o seu dispositivo ligado à ficha de alimentação sempre que possível.**

SUGESTÕES:

Para receber uma assistência mais completa, registre o seu produto.
No caso de um computador, vá a www.archos.com/register.



ARCHOS Mini Cam

Descrição da Minicâmara

- 1 Botão de emparelhamento
- 2 Indicador de emparelhamento
- 3 Lente da câmara
- 4 Microfone
- 5 Autocolante

Instalar a Minicâmara

A câmara funciona com 3 pilhas de lítio CR 24 50.

1. Desaparafuse a bola da câmara.
2. Remova o autocolante de isolamento "remove before use" (remover antes de usar).
3. Aparafuse novamente.
4. Coloque a câmara no seu suporte.
Os ímãs mantêm-na estável. Pode apontar a câmara na direção que desejar.
5. Remova o autocolante do suporte, para colar o dispositivo a uma parede ou ao teto.

Quando mantém o botão de emparelhamento premido (durante 5 segundos)	O LED pisca durante 60 segundos.	O dispositivo procura um tablet para ligação através do modo de emparelhamento.
Quando prime o botão de emparelhamento	O LED pisca durante 10 segundos.	O dispositivo já está emparelhado, mas está desligado. E tenta ligar-se.
	O LED pisca 3 vezes.	O dispositivo não está emparelhado e está desligado.
	O LED fica ligado durante 5 segundos.	O dispositivo está emparelhado e ligado.
	O LED pisca rapidamente.	Está a decorrer uma atualização "over-the-air" (por sinal de rádio).

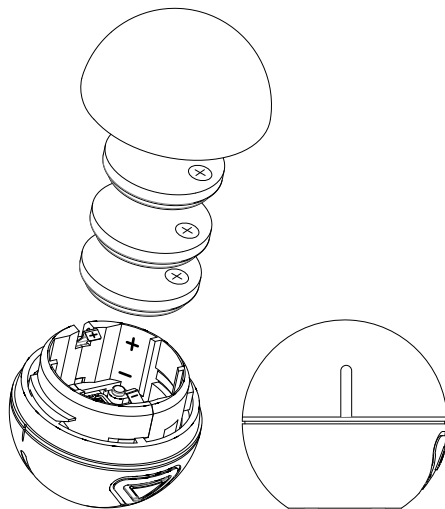
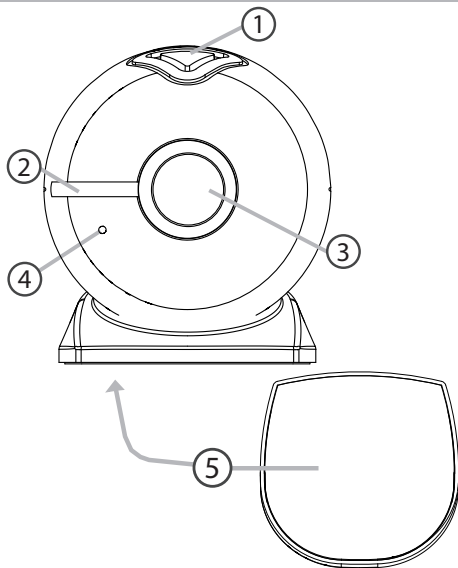

PT

ão

tá

ã

-air"



ARCHOS Weather Tag

Descrição do "Weather tag" (sensor de ambiente)

- 1 Indicador de emparelhamento
- 2 Botão de emparelhamento
- 3 Abertura
- 4 Autocolante

Instalar o "Weather tag" (sensor de ambiente)

O "Weather tag" (sensor de ambiente) funciona com uma pilha de lítio CR 24 30.

1. Remova a cobertura de borracha.
2. Solte o topo da cobertura traseira.
3. Remova o autocolante de isolamento "remove before use" (remover antes de usar).
4. Coloque novamente a cobertura e a borracha traseira.
5. Remova o autocolante da cobertura traseira para colar o dispositivo a uma parede.

Quando mantém o botão de emparelhamento premido (durante 5 segundos)	O LED pisca durante 60 segundos.	O dispositivo procura um tablet para ligação através do modo de emparelhamento.
Quando prime o botão de emparelhamento	O LED pisca durante 10 segundos.	O dispositivo já está emparelhado, mas está desligado. E tenta ligar-se.
	O LED pisca 3 vezes.	O dispositivo não está emparelhado e está desligado.
	O LED fica ligado durante 5 segundos.	O dispositivo está emparelhado e ligado.
	O LED pisca rapidamente.	Está a decorrer uma atualização "over-the-air" (por sinal de rádio).

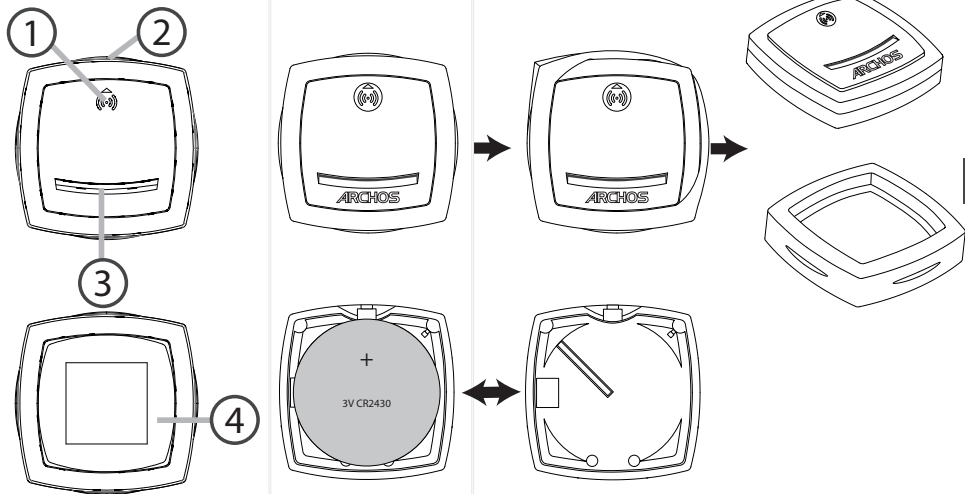

ão

tá

ã

-air"



ARCHOS Movement Tag

Descrição do "Movement tag" (sensor de movimento)

- 1 Ímã
- 2 Sensor do ímã
- 3 Indicador do sensor do ímã
- 4 Botão de emparelhamento
- 5 Indicador de emparelhamento
- 6 Cobertura de borracha
- 7 Autocolante

Instalar o "Movement tag" (sensor de movimento)

O "Movement tag" (sensor de movimento) funciona com uma pilha de lítio CR 24 30.

1. Remova a cobertura de borracha do recetor magnético.
2. Solte o topo da cobertura traseira.
3. Remova o autocolante de isolamento "remove before use" (remover antes de usar).
4. Coloque novamente a cobertura traseira.
5. Remova o autocolante da cobertura traseira para colar o dispositivo a uma parede.
6. Remova o autocolante dos acessórios e cole-os em cima do indicador de posição do ímã.

Quando mantém o botão de emparelhamento premido (durante 5 segundos)

O LED pisca durante 60 segundos.

O dispositivo procura um tablet para ligação através do modo de emparelhamento.

Quando prime o botão de emparelhamento

O LED pisca durante 10 segundos.

O dispositivo já está emparelhado, mas está desligado. E tenta ligar-se.

O LED pisca 3 vezes.

O dispositivo não está emparelhado e está desligado.

O LED fica ligado durante 5 segundos.

O dispositivo está emparelhado e ligado.

O LED pisca rapidamente.

Está a decorrer uma atualização "over-the-air" (por sinal de rádio).

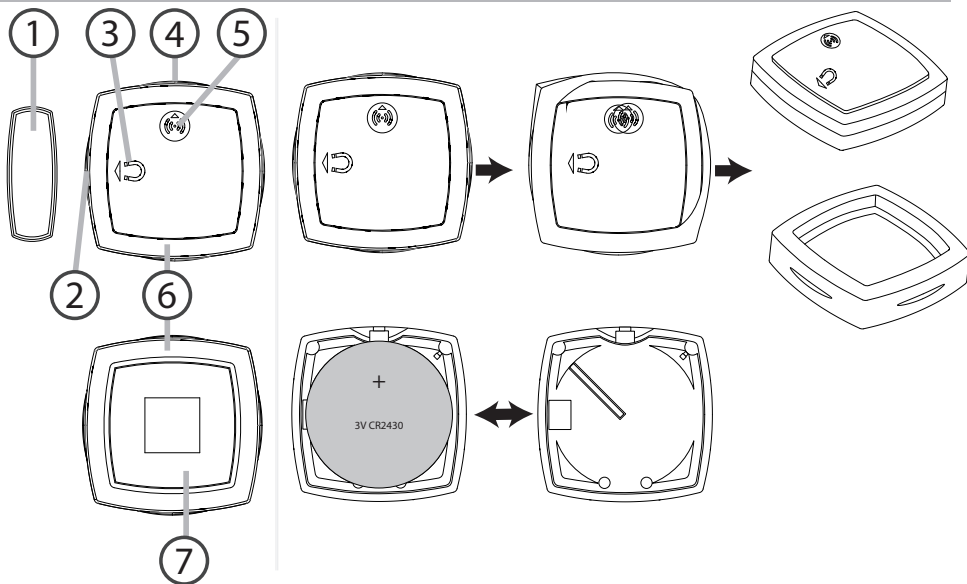

io

á

air"



Descrição do ARCHOS

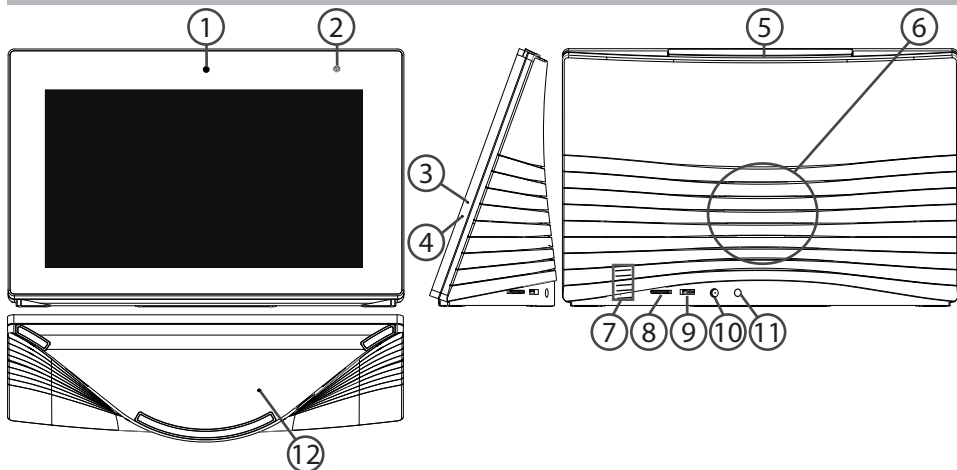

- | | | | |
|----------------------|------------------------|------------------------------|------------------------------|
| ① Webcam | ④ Microfone | ⑦ Sensor da temperatura | ⑩ Ficha de alimentação |
| ② Sensor de luz | ⑤ Botão Ligar/Desligar | ⑧ Ranhura do cartão Micro SD | ⑪ Entrada para auscultadores |
| ③ Indicador de carga | ⑥ Altfalante | ⑨ Porta Micro USB | ⑫ Botão Repor |



Assistente de instalação

Quando iniciar o ARCHOS pela primeira vez, o assistente de instalação irá ajudá-lo a configurar o seu aparelho :

- Idioma
- Rede WiFi
- Configurar uma conta do Google
- Minha localização
- Aplicações de terceiros

PT

SUGESTÕES:

Definir os parâmetros do seu dispositivo na área da rede WiFi você será regularmente usando.



Ligação a uma rede WiFi

AVISO: Certifique-se de que se encontra numa zona WiFi.



① Toque e mantenha premidos os ícones do Tempo e bateria para revelar a barra de estados. Será exibida uma linha azul.



② Puxe a linha azul para baixo para exibir o painel de controlo.



③ Toque em “WiFi off [Wi-Fi desligado]” no painel de controlo.



④ Será exibida a página do WiFi. Se a funcionalidade WiFi estiver desligada, deslize o comutador WiFi para a posição “LIGADO”.

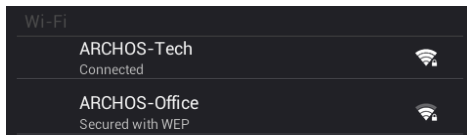



⑤ Depois da funcionalidade WiFi estar ligada, o ARCHOS irá procurar redes WiFi ao alcance. Toque no nome da rede à qual pretende ligar-se. As redes privadas aparecem com o ícone de um cadeado e irão requerer a introdução da sua palavra-passe.

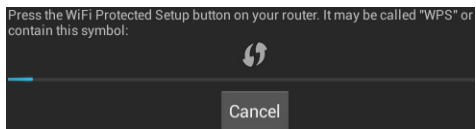

Ligação rápida

Pode ligar à sua rede Wi-Fi através de uma configuração protegida Wi-Fi (WPS).



① Prima o botão configuração de protegida Wi-Fi (WPS)  em "Settings" (Definições) >

② "Wireless & networks" (Wi-Fi e redes).
Prima o botão configuração protegida Wi-Fi (WPS) no seu router da Internet. Poderá ter o símbolo .

PT

SUGESTÕES:

- Recomendamos a seleção da opção "Show password" (mostrar palavra-passe) quando introduz a palavra-passe da rede Wi-Fi, para visualizar os caracteres introduzidos. Contacte o seu fornecedor de Internet (e Wi-Fi), se não souber a palavra-passe ou as definições da sua rede Wi-Fi. Se estiver ao alcance de uma rede Wi-Fi ao qual já tenha ligado o ARCHOS e ela esteja ligada, o ARCHOS tentará ligar-se automaticamente.
- Para manter a ligação Wi-Fi ligada enquanto o dispositivo está suspenso, seleccione o ícone Menu na página Wi-Fi. Depois seleccione "Advanced" (avançado) > "Keep WiFi on during sleep" (manter Wi-Fi ligada enquanto suspenso) > "Always" (sempre).

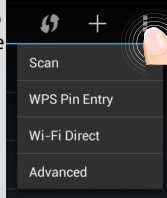



A interface do ARCHOS HOME

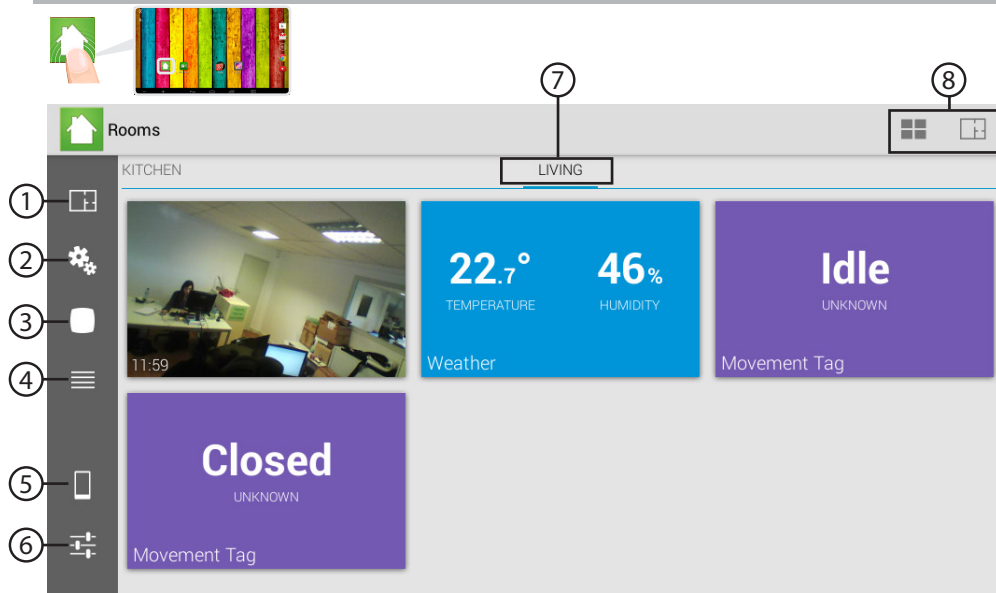



- ① **Separador "Rooms" (divisões):**
Apresenta as divisões da habitação a condizer com as suas configurações.
- ② **Separador "Programs" (programas):**
Apresenta os programas criados para os dispositivos emparelhados.
- ③ **Separador "All accessories" (todos os acessórios):**
Apresenta todos os acessórios emparelhados ao Archos Smart Home Tablet.
- ④ **Separador "History" (histórico):**
Apresenta o histórico das ações dos diferentes acessórios.
- ⑤ **Separador "Connection" (ligação):**
Permite-lhe ligar dispositivos e gerir o Home Tablet à distância.
- ⑥ **Separador "General" (geral):**
Permite-lhe adicionar contas para notificações e gerir as definições.
- ⑦ **Divisão apresentada:**
Apresenta os acessórios em utilização na divisão. Deslize para a direita para ver outras divisões.
- ⑧ **Barra Menu:**
Apresenta menus contextuais dependendo do separador.



ARCHOS HOME: instalação inicial

Será necessário criar divisões, após iniciar a aplicação pela primeira vez. As divisões criadas devem representar as mesmas onde os acessórios foram colocados.

DIVISÕES:

Para criar uma divisão:

- 1 Inicie a aplicação Archos Home.
- 2 Seleccione "Add a room" (adicionar divisão).
- 3 Introduza o nome para a divisão e seleccione OK.

Pode criar tantas divisões quanto desejar.

- 4 Para finalizar, seleccione "Done" (concluir).



Rooms



Add a room

Done



EMPARELHAMENTO

Pode emparelhar acessórios ao tablet, após criar as divisões.

Para emparelhar um acessório:

- 1 Verifique se o Bluetooth do tablet está ligado. Se não estiver, ligue-o indo a "Settings" (Definições) > "Wireless & networks" (Wi-Fi e redes).
- 2 Selecione o acessório desejado.

Verifique se removeu das pilhas o autocolante de isolamento "remove before use" (remover antes de usar).

- 3 Mantenha o botão de emparelhamento do acessório premido durante 5 segundos.

O indicador de emparelhamento começará a piscar.

- 4 Prima o botão "Start" (Iniciar) no tablet.

Isto iniciará o processo de emparelhamento.

Se o emparelhamento for bem-sucedido, será apresentada a seguinte mensagem: **"Successfully paired!" (Emparelhamento bem-sucedido)**
"Press OK to continue" (selecione OK para continuar)

Successfully paired!
Press OK to continue

- 5 Selecione OK.

Terá a oportunidade de associar o dispositivo a uma divisão existente.



ARCHOS HOME: instalação inicial

Se o emparelhamento falhar, será apresentada a seguinte mensagem:

Timeout
Press Cancel to continue

Tem o Bluetooth do tablet ligado?

- 1 Seleccione a aplicação "Settings" (Definições) no tablet.
- 2 Depois reinicie o Bluetooth na secção "Wireless & networks" (Wi-Fi e redes).

O indicador de emparelhamento do acessório está a piscar?

Mantenha o botão de emparelhamento do acessório premido durante 5 segundos, para ligá-lo.

Isto deverá reiniciar o emparelhamento.

SUGESTÕES:

Quando mantém o botão de emparelhamento premido (durante 5 segundos)

O LED pisca durante 60 segundos: O dispositivo procura um tablet para ligação através do modo de emparelhamento.

Quando prime o botão de emparelhamento

O LED pisca durante 10 segundos: O dispositivo já está emparelhado, mas está desligado. E tenta ligar-se.

O LED pisca 3 vezes: O dispositivo não está emparelhado e está desligado.

O LED fica ligado durante 5 segundos: O dispositivo está emparelhado e ligado.

O LED pisca rapidamente: Está a decorrer uma atualização "over-the-air" (por sinal de rádio).



NOMES

É necessário dar um nome ao acessório, após o seu emparelhamento.

Para dar o nome a um acessório:

1	Introduza um nome relevante ao acessório.
---	---

Escolha um nome para fácil identificação do acessório e da sua posição na habitação.

2	Selecione OK.
---	---------------

PT

ASSOCIAÇÕES

Podemos escolher as divisões onde pretende utilizar o dispositivo, depois de lhes dar um nome.

Para associar um acessório a uma divisão:

1	Verifique a(s) divisão(ões) selecionada(s).
---	---

2	Selecione "Done" (concluir).
---	------------------------------

Os acessórios serão apresentados no separador "All accessories" (todos os acessórios), após concluir a configuração.



A interface dos acessórios

Separador "All accessories" (todos os acessórios)



The screenshot shows a mobile application interface for managing accessories. At the top, there's a header with 'All accessories' and 'Sort by room'. Below this, a list of accessories is displayed. Each item has a battery level indicator, an online status icon, and a room name. A legend on the right side explains the icons used in the interface.

①	Nome da secção.
②	Tipo da ordenação.
③	Qualidade da ligação Bluetooth.
④	Adicionar mais acessórios.
⑤	- Nível da bateria. - Estado da ligação. - Divisão correspondente.





Gestão dos acessórios

Como é que posso criar mais divisões?

- 1 Seleccione a secção "Rooms" (divisões) , na aplicação Archos Home.
- 2 Seleccione o ícone  das divisões, na barra do menu da secção "Rooms" (divisões).
- 3 Seleccione "Add a room" (adicionar divisão) e introduza o nome para a divisão.
Para finalizar, seleccione "Done" (concluir).



Como é que posso modificar uma divisão já criada?



- 1 Seleccione a secção "Rooms" (divisões), na aplicação Archos Home.
- 2 Seleccione o ícone  na barra do menu da secção "Rooms" (divisões).
- 3 Seleccione o ícone  ao lado de cada divisão, para modificar ou eliminá-la.
- 4 Para finalizar, seleccione "Done" (concluir).

PT



Gestão dos acessórios

Como é que posso emparelhar mais acessórios?

- 1 Seleccione a secção "All accessories" (todos os acessórios)  na aplicação Archos Home.
 - 2 Seleccione o ícone  na barra do menu da secção "All accessories" (todos os acessórios).
 - 3 Seleccione o tipo de acessório que deseja emparelhar ao tablet.
- Verifique se removeu das pilhas o autocolante de isolamento "remove before use" (remover antes de usar).
- 4 Mantenha o botão de emparelhamento do acessório premido durante 5 segundos.
- O indicador de emparelhamento começará a piscar.
- 5 Prima o botão "Start" (Iniciar) no tablet.
- Isto iniciará o processo de emparelhamento.
- Seleccione "OK" se for bem-sucedido ou "Restart" (reiniciar) caso falhe. Consulte a secção anterior acerca dos acessórios.

All accessories 



Accessories

Click on the accessory type you want to pair





Como é que modifico o nome a um acessório?



- 1 Seleccione a secção "All accessories" (todos os acessórios) , na aplicação Archos Home.
- 2 Seleccione o acessório  que pretende modificar, na secção "All accessories" (todos os acessórios).

Será apresentada uma lista de opções.

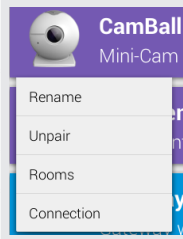
- 3 Seleccione "Rename" (modificar nome), seguido de OK.



Como é que associo um acessório a uma divisão?

- 1 Seleccione a secção "All accessories" (todos os acessórios) , na aplicação Archos Home.
- 2 Seleccione o acessório  que pretende modificar, na secção "All accessories" (todos os acessórios).

Será apresentada uma lista de opções.

- 3 Seleccione "Rooms" (divisões):
- 4 Seleccione a(s) divisão(ões) desejada(s), seguido de OK.

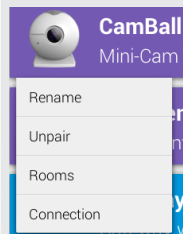

PT



Ligação a dispositivos móveis

Pode gerir o seu Archos Smart Home Tablet através do seu dispositivo móvel, mesmo que não esteja em casa.

Transferir a aplicação

- 1 Transfira a aplicação Archos Home através da Play Store, da App Store, ou analisando o código QR.
- 2 Inicie a aplicação após a transferência.

Serão apresentadas duas opções de ligação para o Archos Smart Home Tablet, após iniciar a aplicação.

Ligação através da mesma rede Wi-Fi:

- 1 Selecione a opção "**if you are on the same home network than the Archos Home Gateway**" (se estiver na mesma rede local que o ponto de ligação Archos Home).



Será apresentada a mensagem "**Looking for the Archos Home Gateways in your local network**" (a procurar o ponto de ligação Archos Home na sua rede local). O Archos Smart Home Tablet será apresentado, logo que seja detetado.

E tenta ligar-se.



Archos Home Tablet
192.168.86.125
Press to connect

É enviado um pedido de emparelhamento para o Home Tablet.

Selecione "**Allow**" (permitir) no Home Tablet, para autorizar o dispositivo.

You now need to accept the authorization request on the Archos Home Gateway

Isto dará início ao processo de ligação. Quando o seu dispositivo estiver ligado ao Home Tablet, pode gerir o tablet de onde quiser.



Archos Home Tablet
192.168.86.125
You are currently connected to this gateway



Ligação via 3G ou outra rede Wi-Fi:

1	Selecione a opção " If you are on a remote connection " (se estiver numa ligação remota).	
Será solicitado um código para ligar ao Home Tablet.		
2	No Home Tablet, inicie a aplicação Archos Home e selecione o separador "Connection" (ligação).	
3	Selecione " Authorize a device " (autorizar dispositivo) na barra do Menu, no separador "Connection" (ligação).	
Será fornecido um código de 32 dígitos. Deverá introduzi-lo no dispositivo que pretende ligar ao Home Tablet.		
4	Introduza o código de 32 dígitos como requisitado.	
Isto dará início ao processo de ligação. Quando o seu dispositivo estiver ligado ao Home Tablet, pode gerir o tablet à distância.		



Programas:

Pode criar programas, após emparelhar acessórios ao Home Tablet.





Um programa é uma ação iniciada por um acionador e agendada para um certo período de tempo.

A interface de um programa

- 1 Nome do programa.
- 2 O "trigger" (acionador) é um evento que cria uma sequência de ações.
- 3 A duração define o tempo limite de uma ação.
- 4 As ações são acionadas por eventos.
- 5 O período de validade da sequência de ações é definido por um horário.
- 6 Utilize "Save" (guardar) para confirmar o programa, ou "Cancel" (cancelar) para interromper a sua criação.

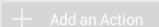

Para criar um programa:

- 1 Inicie a aplicação Archos Home .
 - 2 Selecione a secção "Programs" (programas)  na aplicação Archos Home.
 - 3 Selecione  na barra do Menu.
- Será apresentada uma janela para criar um programa:
- 4 Introduza um nome.
 - 5  : poderá ser um horário, uma deteção ou um evento atmosférico.
 - 6  : poderá ser uma notificação, uma imagem ou um vídeo. Pode definir a duração da ação.
 - 7 Selecione um período de tempo para a ocorrência do evento.
 - 8 Selecione "**SAVE**" (guardar).

O programa será criado e estará ativo.

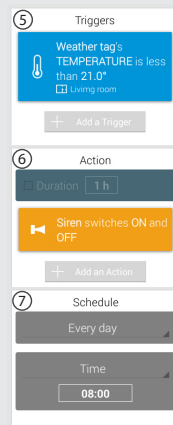

5 Triggers

Weather tag's TEMPERATURE is less than 21.0°
 Living room

+ Add a Trigger

6 Action

Duration: 1 h

 Siren switches ON and OFF

+ Add an Action

7 Schedule

Every day

Time

08:00



Check weather

 ON

When Weather tag's TEMPERATURE is less than 21.0°
Siren switches ON and OFF



Every day Starts at 08:00

PT



Programas:

Para modificar um programa:

- 1 Inicie a aplicação Archos Home .
 - 2 Selecione a secção "Programs" (programas)  na aplicação Archos Home.
 - 3 Selecione o programa que deseja modificar.
- Serão apresentadas as opções do programa.
- 4 Selecione "Edit" (editar).
 - 5 Efetue as modificações desejadas.
 - 6 Selecione "**SAVE**" (guardar).

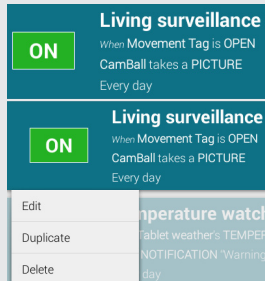



ON Living surveillance
When Movement Tag is OPEN
CamBall takes a PICTURE
Every day

ON Living surveillance
When Movement Tag is OPEN
CamBall takes a PICTURE
Every day

Edit temperature watch
Duplicate Tablet weather's TEMPER
Delete NOTIFICATION Warning
day

Para ligar/desligar um programa:

- 1 Inicie a aplicação Archos Home .
 - 2 Selecione a secção "Programs" (programas)  na aplicação Archos Home.
 - 3 Selecione o programa que deseja ligar.
 - 4 Prima **ON** para desligar o programa **OFF**.
- 244 Prima **OFF** para o voltar a ligar **ON**.



As interações do Archos Home

Os seus acessórios estão emparelhados ao Home Tablet. O tablet apresentará os dados de cada acessório.



Os programas criados no seu tablet criarão interações entre ele e os acessórios.
Os quadrados de informação no separador "Rooms" (divisões), correspondem a acessórios específicos.



O histórico dos dados é apresentado quando toca num quadrado de informação.

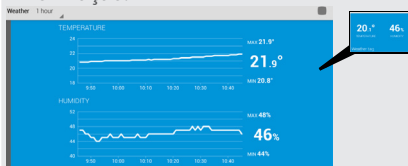

A aplicação Archos Home facilita a gestão remota do Home Tablet e seus acessórios, através do seu dispositivo móvel.



PT



A Interface Android™

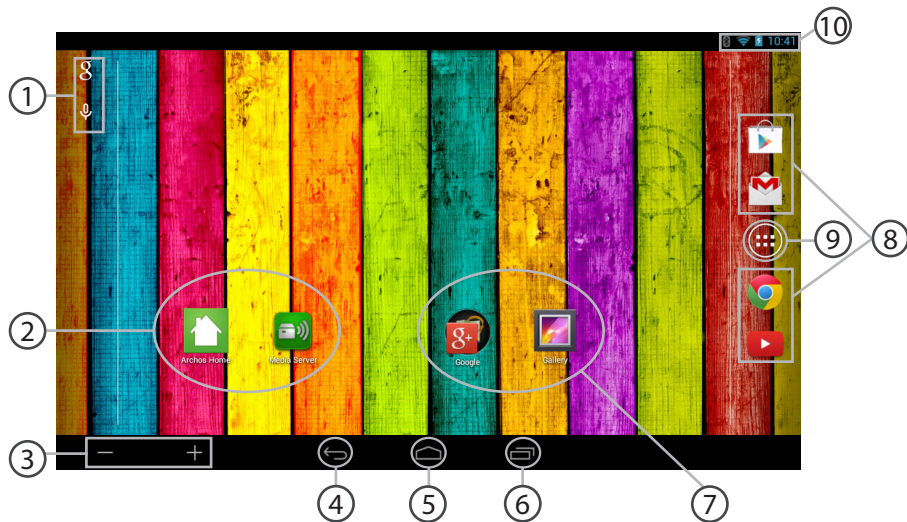



- ① **Google™ Search**
> Toque para efectuar uma pesquisa de texto ou uma busca por voz.
- ② **Aplicações ARCHOS**
- ③ **Botões de volume**
- ④ **“Anterior”**
- ⑤ **“Ecrã Principal”**
- ⑥ **“Aplicações recentes”**
- ⑦ **Atalhos para aplicações Google**
> Toque para iniciar a aplicação.
- ⑧ **Atalhos permanentes em aplicações Android™**
- ⑨ **“Todas as Aplicações”**
> Toque neste ícone para visualizar todas as aplicações e widgets instalados no seu ARCHOS. Estão aqui todas as aplicações descarregadas.
- ⑩ **Barra do estado**
> Apresenta notificações e definições rápidas.



A Interface Android™

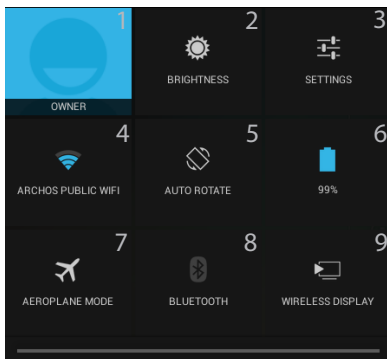

3:18 As Definições rápidas

- 1 Utilizador atual⁽¹⁾
- 2 Para ajustar o brilho do ecrã.
- 3 Para aceder a todas as suas definições.
- 4 Para ligar/desligar a sua ligação WiFi.
- 5 Para activar/desactivar a orientação automática do ecrã enquanto roda o ARCHOS.
- 6 Ver a percentagem de bateria que resta
- 7 Para activar/desactivar todas as ligações sem fios, especialmente durante voos.
- 8 Você pode exibir a interface Bluetooth
- 9 Para ligar a visualização sem fios⁽²⁾.

⁽¹⁾O novo suporte multiutilizador para permite que diferentes utilizadores tenham áreas de trabalho separadas e personalizadas no mesmo dispositivo. Pode adicionar utilizadores em Settings > Device [Definições > Dispositivo]

⁽²⁾Pode partilhar filmes, vídeos do YouTube e tudo o que estiver no seu ecrã com uma televisão HD. Basta que ligue um adaptador de visualização sem fios numa TV com HDMI e poderá espelhar tudo o que está no ecrã do seu tablet, rápido e facilmente.



Aplicações recentes

Abre uma lista de imagens em tamanho reduzido das aplicações que utilizou recentemente:

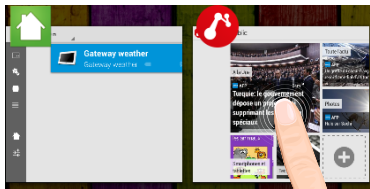

Toque: para abrir uma aplicação

Manter premido: exibir opções

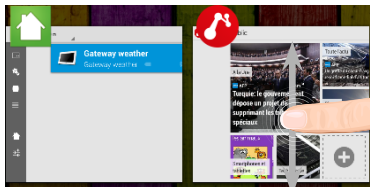

Deslizar para cima ou para baixo: fechar uma aplicação

PT



Familiarizar-se com Android™

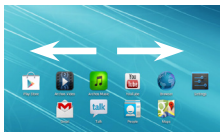

O ecrã inicial alargado:

Navegue entre os diferentes painéis do ecrã inicial movendo-os para a esquerda e para a direita.

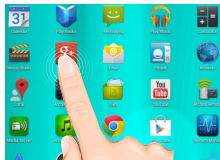

Mover um item do ecrã inicial:

Toque continuamente com o dedo no mesmo até aparecer a grelha de posicionamento; em seguida, deslize-o para a posição pretendida e solte o dedo.

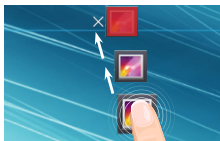

Remover um item do ecrã inicial:

Toque continuamente no mesmo, deslize o seu dedo para o topo do ecrã e largue-o sobre o ícone Remover.

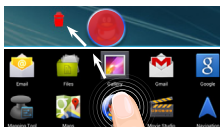

Desinstalar um item:

A partir do ecrã Todas as aplicações, toque continuamente no mesmo, deslize o seu dedo para o topo do ecrã e largue-o sobre o caixote Desinstalar.



Criar pastas de aplicações:

Largue o ícone de uma aplicação sobre outro num ecrã inicial e os dois ícones ficarão combinados.



Widgets:

Toque no ícone Todas as aplicações no seu ecrã inicial. Toque em Widgets no topo do ecrã. A partir do ecrã Widgets principal, pode movimentar os widgets da mesma forma que o faz com os ícones das aplicações.

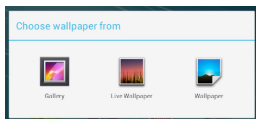

Alterar a imagem de fundo:

Mantenha o dedo no ecrã sobre uma localização vazia, em seguida seleccione a partir da lista.

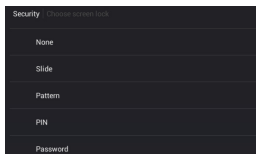

Bloquear o ecrã táctil:

A partir do painel de definições rápidas na barra do estado, toque nas definições. Desloque para baixo e toque em Segurança. Toque em Bloquear ecrã. Toque no tipo de bloqueio que pretende utilizar. Depois de definir aqui um bloqueio, será apresentado um ecrã de bloqueio sempre que activar o ecrã, a solicitar o padrão, o PIN ou outra chave especificada.



Resolução de problemas

O que posso fazer, caso o Bluetooth não funcione corretamente?

Dirija-se a "Settings" (Definições) > "Wireless & networks" (Wi-Fi e redes) e selecione Bluetooth. Selecione "Click to restart Bluetooth" (Prima para reiniciar o Bluetooth).

Por que motivo não posso ligar o meu dispositivo móvel ao Home Tablet?

Poderá estar ligado a uma rede protegida com firewall. Nesse caso, não conseguirá estabelecer a ligação ao Home Tablet.

Por que motivo os meus acessórios não estão a responder?

Eles estão emparelhados corretamente ao Home Tablet?

Verifique se o Bluetooth do tablet está ligado.

Verifique se as pilhas estão vazias. Nesse caso, terá de trocá-las.

Por que motivo não posso adicionar mais acessórios?

Pode emparelhar apenas 13 acessórios ao Home Tablet.

Se ainda não tiver alcançado esse número, verifique se o Bluetooth do tablet está ligado e se as pilhas dos acessórios estão vazias.

Como posso restaurar as definições predefinidas do dispositivo?

1. Ligue o cabo de alimentação à ficha de alimentação do dispositivo, com este desligado.

2. Assim que o logótipo ARCHOS for apresentado, mantenha o botão Repor premido durante 5 segundos, com a ponta de um clipe de papel.

Será apresentada a interface de recuperação do Android.

3. Toque na opção desejada.

4. Utilize o botão Ligar/Desligar para confirmar.

- Selecione "Wipe data/factory reset" (limpar dados/reposição de fábrica) para confirmar e restaurar as definições predefinidas do seu dispositivo.
- Selecione "Yes -- delete all user data" (sim, eliminar todos os dados do utilizador) e confirme para eliminar todos os dados do utilizador.
- Selecione "Reboot system now" (reiniciar o sistema agora) e confirme para reiniciar o dispositivo.

Bluetooth

Click to restart Bluetooth



Содержание

Содержимое упаковки.....	254
Начало работы.....	255
Мини-Камера ARCHOS.....	256
Датчик погоды ARCHOS.....	258
Датчик движения ARCHOS.....	260
Описание планшета ARCHOS Smart Home.....	262
Следуя указаниям мастера.....	263
Подключение к сети WiFi.....	264
Интерфейс ARCHOS Home.....	266
ARCHOS HOME - Первоначальная настройка.....	268
Интерфейс устройств.....	272
Управление устройствами.....	273
Подключение с помощью вашего мобильного телефона.....	276
Программы.....	278
Взаимодействие с ARCHOS Home.....	281
Интерфейс Android™.....	282
Знакомство с Android™.....	286
Поиск и устранение неисправностей.....	288

За дополнительную информацией обратитесь к разделу часто задаваемых вопросов сайте www.archos.com. Обязательно прочтите их прежде, чем задумываться о возврате изделия. Ваша проблема может оказаться не столь уж значительной.



Содержимое упаковки

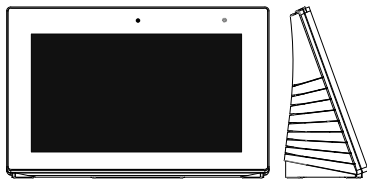

ARCHOS Smart Home Tablet



Mini Cam
X 2



Weather Tag
X 2



Movement Tag
X 2



Кабель USB



Зарядное устройство



Краткое руководство



Гарантии и
инструкции по
безопасности



Начало работы

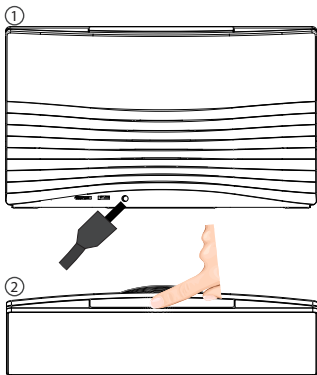

1. Подключите кабель блока питания к разъему питания. При подключении кабеля питания загорается голубой индикатор питания. Устройство начинает заряжаться.
2. Нажмите кнопку ON/OFF, чтобы включить устройство.
 - Вы можете пользоваться вашим ARCHOS, пока он заряжается.
 - При первом использовании позвольте вашему устройству полностью зарядиться.
 - Разрешается использовать только зарядное устройство из комплекта поставки.



По возможности используйте ваше устройство с подключенным блоком питания.

СОВЕТ:

Зарегистрируйте свое изделие, чтобы получать обслуживание в более полном объеме. При работе с компьютером перейдите по ссылке www.archos.com/register.

RU



ARCHOS Mini cam

Описание Мини-Камеры

- 1 Кнопка привязки
- 2 Индикатор привязки
- 3 Линза камеры
- 4 Микрофон
- 5 Наклейка

Установка Мини-Камеры

Ваша камера работает на 3 литиевых батарейках типа CR 24 50.

1. Отвинтите крышку камеры.
2. Удалите защитную наклейку «Снять перед использованием».
3. Верните винт на место.
4. Поместите камеру на подставку. Магниты удерживают ее неподвижно. Вы можете перемещать камеру в любом направлении.
5. Удалите наклейку на подставке, чтобы прикрепить устройство к стене или потолку.

Когда вы удерживаете кнопку Pairing (Привязка) (5 секунд)	Индикатор мигает 60 секунд	Устройство находится в режиме привязки и пытается соединиться с планшетом.
Когда вы кратковременно нажимаете кнопку Pairing (Привязка)	Индикатор мигает 10 секунд	Устройство уже привязано, но отключено. Устройство пытается подключиться.
	Индикатор мигает 3 раза	Устройство не привязано и отключено.
	Индикатор горит в течение 5 секунд	Устройство привязано и подключено.
	Индикатор быстро мигает	Производится обновление по радио.

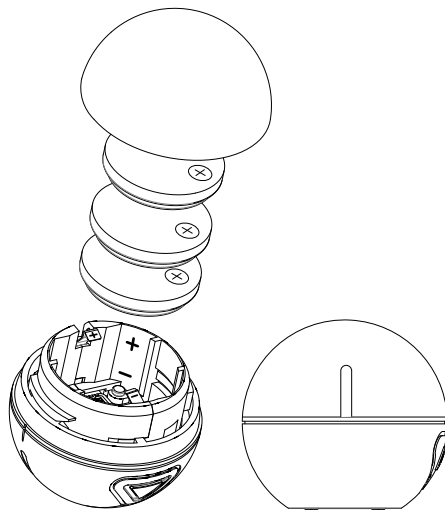
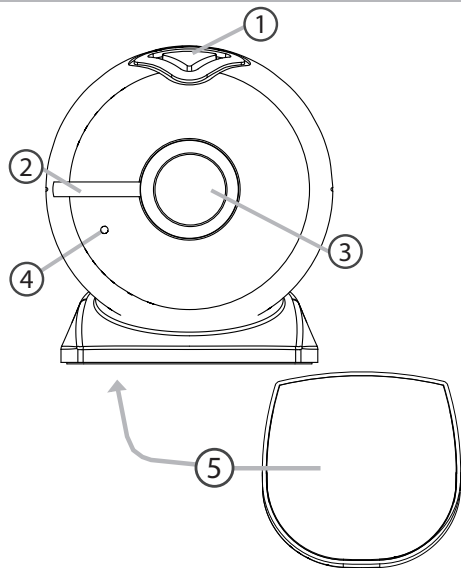

RU



ARCHOS Weather Tag

Описание датчика погоды

- 1 Индикатор привязки
- 2 Кнопка привязки
- 3 Контакты
- 4 Наклейка

Установка датчика погоды

Ваша датчик погоды работает на литиевой батарее типа CR 24 30.

1. Удалите резиновый чехол.
2. Отсоедините верхнюю часть задней крышки.
3. Удалите защитную наклейку «Снять перед использованием».
4. Установите обратно заднюю крышку и резиновый чехол.
5. Удалите наклейку на задней крышке, чтобы прикрепить устройство к стене или потолку.

Когда вы удерживаете кнопку Pairing (Привязка) (5 секунд)	Индикатор мигает 60 секунд	Устройство находится в режиме привязки и пытается соединиться с планшетом.
Когда вы кратковременно нажимаете кнопку Pairing (Привязка)	Индикатор мигает 10 секунд	Устройство уже привязано, но отключено. Устройство пытается подключиться.
	Индикатор мигает 3 раза	Устройство не привязано и отключено.
	Индикатор горит в течение 5 секунд	Устройство привязано и подключено.
	Индикатор быстро мигает	Производится обновление по радио.

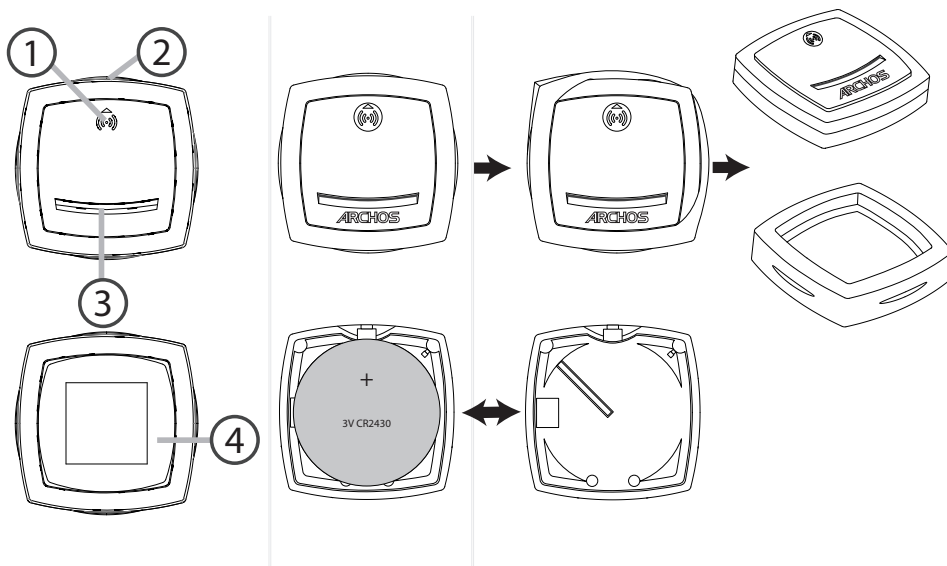



ARCHOS Movement Tag

Описание датчика движения

- 1 Магнит
- 2 Магнитный датчик
- 3 Индикатор магнитного датчика
- 4 Кнопка привязки
- 5 Индикатор привязки
- 6 Резиновый чехол

Установка датчика движения

Ваш датчик движения работает на литиевой батарееке типа CR 24 30.

1. Снимите резиновый корпус магнитного приемника.
2. Отсоедините верхнюю часть задней крышки.
3. Удалите защитную наклейку «Снять перед использованием».
4. Установите обратно заднюю крышку.
5. Удалите наклейку на задней крышке, чтобы прикрепить устройство к стене или потолку.
6. Удалите наклейки на устройствах для прикрепления их напротив магнитного датчика положения.

Когда вы удерживаете кнопку Pairing (Привязка) (5 секунд)	Индикатор мигает 60 секунд	Устройство находится в режиме привязки и пытается соединиться с планшетом.
Когда вы кратковременно нажимаете кнопку Pairing (Привязка)	Индикатор мигает 10 секунд	Устройство уже привязано, но отключено. Устройство пытается подключиться.
	Индикатор мигает 3 раза	Устройство не привязано и отключено.
	Индикатор горит в течение 5 секунд	Устройство привязано и подключено.
	Индикатор быстро мигает	Производится обновление по радио.

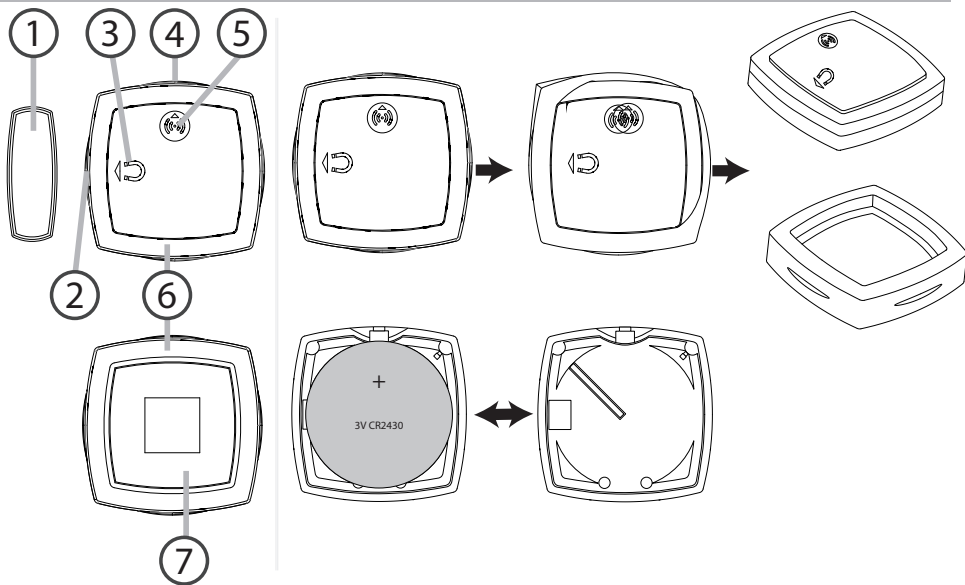



Описание устройства

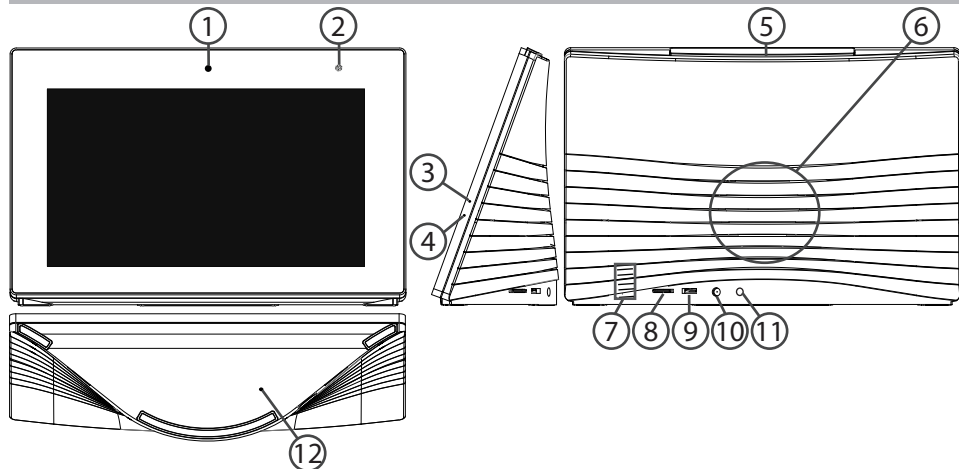

① Веб-камера

④ Микрофон

⑦ Температурный датчик

⑩ Разъем питания

② Датчик освещенности

⑤ Кнопка включения и выключения

⑧ Слот карты Micro-SD

⑪ Разъем наушников

③ Индикатор зарядки

⑥ Громкоговоритель

⑨ Порт micro-USB

⑫ Кнопка сброса



Мастер настройки

При первом запуске устройства ARCHOS мастер установки поможет выполнить настройку :

- Язык
- Соединение Wi-Fi
- Настройка учетной записи Google
- Опции службы геолокации
- Сторонние приложения

RU

СОВЕТ:

Мы рекомендуем выполнять настройку устройства в зоне Wi-Fi сети, которой Вы будете регулярно пользоваться.



Подключение к сети Wi-Fi

ВНИМАНИЕ: Убедитесь, что Вы находитесь в зоне покрытия Wi-Fi.

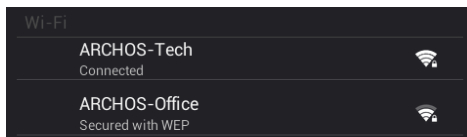
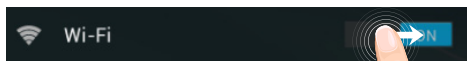

① Коснитесь и удерживайте значки времени и аккумулятора, чтобы открыть строку состояния. Отобразится синяя линия.

② Потяните синюю линию вниз, чтобы отобразить панель мониторинга состояния.

③ Коснитесь пункта «Wi-Fi off [Wi-Fi выкл.]» на панели мониторинга состояния. Отобразится страница Wi-Fi.

④ Если связь Wi-Fi выключена, переместите переключатель Wi-Fi в положение ON (ВКЛ).

⑤ После включения устройство ARCHOS выполнит поиск доступных сетей Wi-Fi. Выберите ту сеть, к которой хотите подключиться. Частные сети отображаются в виде значка с замком, и для них потребуется ввести пароль.





Быстрое подключение

Вы можете подключить вашу сеть WiFi через мастер настройки безопасного подключения WiFi.

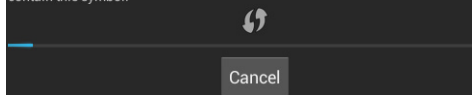
Press the WiFi Protected Setup button on your router. It may be called "WPS" or contain this symbol:



- 1 Нажмите кнопку WiFi Protected Setup  в разделе Settings > Wireless & networks (Настройки > Беспроводные и проводные сети).
- 2 На вашем Интернет-роутере нажмите кнопку WiFi Protected Setup, так называемую WPS, или содержащую символ .

СОВЕТЫ:

- При наборе пароля сети WiFi советуем включать «Show password» (Отображение пароля), чтобы вы могли видеть набираемые символы. Для получения пароля сети WiFi (или ее настроек), обратитесь к провайдеру этой сети WiFi. Если ваша сеть WiFi включена и вы находитесь в зоне покрытия сети, к которой уже подключились, ваш ARCHOS постарается подключиться к ней автоматически.
- Для включения режима удержания WiFi-подключения, даже когда устройство переходит в спящий режим, нажмите значок Menu (Меню) на странице «WiFi». Затем, выберите Advanced > Keep WiFi on during sleep > Always (Дополнительные настройки > Удерживать WiFi включенным в режиме сна > Всегда).

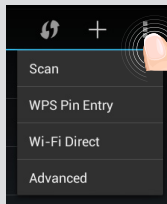

RU



Интерфейс ARCHOS HOME

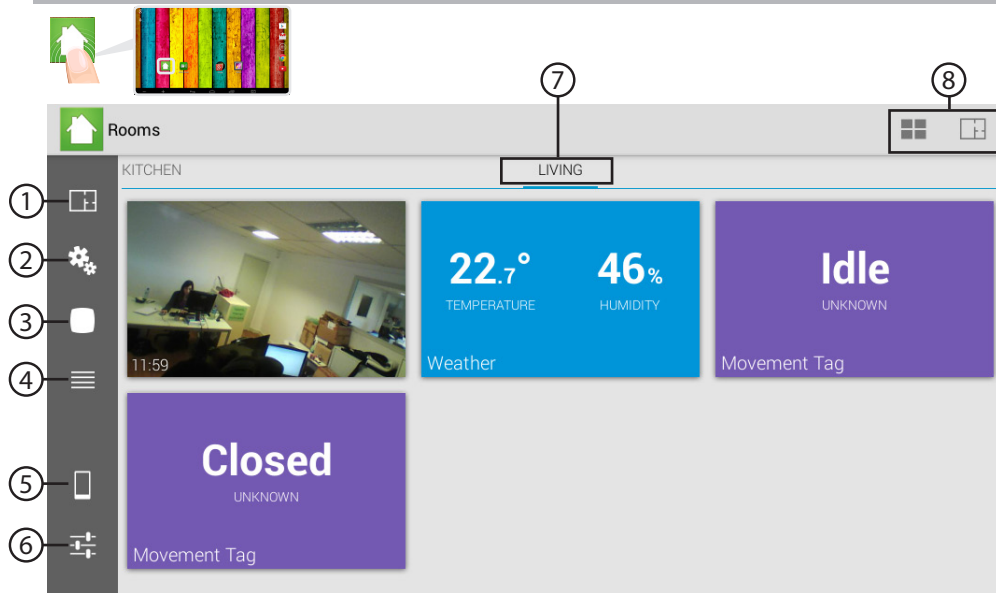



- ① **Вкладка Rooms (Комнаты):**
отображает комнаты, которые вы создали в соответствии с комнатами вашего дома.
- ② **Вкладка Programs (Программы):**
отображает программы, работающие со связанными объектами.
- ③ **Вкладка All accessories (Все устройства):**
отображает все устройства, связанные с планшетом Archos Smart Home.
- ④ **Вкладка History (История):**
отображает журнал событий из различных устройств.
- ⑤ **Вкладка Connection (Подключение):**
позволяет вам подключать устройства и управлять домашним планшетом удаленно.
- ⑥ **Вкладка General (Основная):**
позволяет вам добавлять адреса для уведомлений и управлять настройками.
- ⑦ **Содержимое комнаты:**
отображает устройства, расположенные в этой комнате. Проведите по экрану вправо для отображения других комнат.
- ⑧ **Строка меню:**
отображает кнопки контекстного меню в зависимости от выбранной вкладки.



ARCHOS HOME - Первоначальная настройка

После первого запуска приложения, вам потребуется создать комнаты. Создаваемые вами комнаты должны соответствовать реальным комнатам, в которых размещены устройства.

Комнаты

Чтобы создать комнату		
1	Запустите приложение Archos Home.	
2	Выберите Add a room (Добавить комнату).	
3	Введите название комнаты и выберите ОК.	
Вы можете создать столько комнат, сколько захотите.		
4	В заключение выберите Done (Готово).	



ПРИВЯЗКА

После создания комнат, следующий шаг позволит вам привязать устройства к вашему планшету.

Для привязывания устройства

1 Проверьте, чтобы Bluetooth планшета был включен. Если нет, включите его через Settings > Wireless & Networks (Настройки > Беспроводные и проводные сети).

2 Выберите нужное устройство.

Убедитесь, что вы удалили защитную наклейку «удалить перед использованием» с батареек.

3 Удерживайте кнопку привязки на устройстве в течение 5 секунд.

Индикатор привязки начинает мигать.

4 Нажмите кнопку Start (Пуск) на планшете.

Начинается процесс привязки.

Если привязка удалась, отобразится следующее сообщение:
Successfully paired! (Привязка успешно выполнена!) Нажмите ОК для продолжения

Successfully paired!
Press OK to continue

5 Нажмите ОК.

Вам будет предложено привязать устройство к существующей комнате.

RU



ARCHOS HOME - Первоначальная настройка

Если процесс привязки не удался, вы увидите следующее сообщение:

Timeout
Press Cancel to continue

Is Bluetooth turned ON in the tablet? (Bluetooth планшета включен?)

- 1 Запустите приложение Settings (Настройки) на планшете.
- 2 В разделе Wireless & networks (Беспроводные и проводные сети) перезапустите Bluetooth.

Индикатор привязки на устройстве мигает?

Чтобы его включить, удерживайте кнопку привязки на устройстве в течение 5 секунд.

Необходимо повторить процедуру привязки.

СОВЕТЫ:

Когда вы удерживаете кнопку Pairing (Привязка) (5 секунд)

Индикатор мигает в течение 60 секунд: устройство находится в режиме привязки и пытается соединиться с планшетом.

Когда вы кратковременно нажимаете кнопку Pairing (Привязка)

Индикатор мигает в течение 10 секунд: Устройство уже привязано, но отключено. Устройство пытается подключиться.

Индикатор мигает 3 раза: устройство не привязано и отключено.

Индикатор горит в течение 5 секунд: устройство привязано и подключено.

Индикатор быстро мигает: производится обновление по радио.

**a**

Присвоение имени

После привязки необходимо ввести имя устройства.

Для присвоения имени устройству

1 Введите имя, соответствующее устройству.

Необходимо выбрать имя, которое поможет легко идентифицировать устройство и его положение в вашем доме.

2 Нажмите ОК.

RU

УСТАНОВЛЕНИЕ СВЯЗИ

После присвоения имени можно выбрать комнаты, в которых вы хотите показывать устройство.

Чтобы связать устройство с комнатой

1 Проверьте выбранную комнату(ы).

2 Выберите Done (Готово).

После окончания настройки ваши устройства отображаются во вкладке All accessories (Все устройства).



Интерфейс устройств



Вкладка All accessories (Все устройства):

①	Название раздела
②	Тип сортировки
③	Качество соединения Bluetooth
④	Добавление дополнительных устройств
⑤	<ul style="list-style-type: none">- Уровень заряда батареи- Статус соединения- Комната, в которой находится устройство



Управление устройствами

Каким образом можно создать больше комнат?



- 1 В приложении Archos Home выберите раздел Rooms (Комнаты) .
- 2 В разделе Rooms (Комнаты) выберите значок Rooms (Комнаты)  в строке меню.
- 3 Выберите Add a room (Добавить комнату) и введите имя комнаты.
Выберите Done (Готово), если вы закончили.

Rooms



RU

Каким образом можно изменить уже созданную комнату?

- 1 В приложении Archos Home выберите раздел Rooms (Комнаты).
- 2 В разделе Rooms (Комнаты) выберите значок  в строке меню.
- 3 Рядом с именем каждой существующей комнаты выберите , чтобы изменить или удалить комнату.
- 4 Выберите Done (Готово), если вы закончили.



Управление устройствами

Каким образом можно привязать больше устройств?

1 В приложении Archos Home выберите раздел All accessories (Все устройства) .

2 В разделе All accessories (Все устройства) выберите значок  в строке меню.

3 Выберите тип устройства, который вы хотите привязать к планшету.

Убедитесь, что вы удалили защитную наклейку «удалить перед использованием» с батареек.

4 Удерживайте кнопку привязки на устройстве в течение 5 секунд.

Индикатор привязки начинает мигать.

5 Нажмите кнопку Start (Пуск) на планшете.

Начинается процесс привязки.

Выберите ОК, если процесс привязки успешно выполнен, или повторите процесс в случае неудачи. См. предыдущий раздел устройств.

All accessories 

Accessories

Click on the accessory type you want to pair





Каким образом можно переименовать устройство?

1 В приложении Archos Home выберите раздел All accessories (Все устройства) .

2 В разделе All accessories (Все устройства) выберите устройство , которое хотите переименовать.

Отображается список вариантов.

3 Выберите Rename (Переименовать), затем ОК.

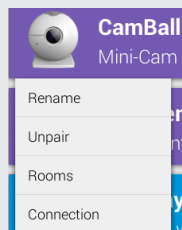

Каким образом можно связать устройство с комнатой?

1 В приложении Archos Home выберите раздел All accessories (Все устройства) .

2 В разделе All accessories (Все устройства) выберите устройство , которое хотите переименовать.

Отображается список вариантов.

3 Выберите «Rooms» (Комнаты).

4 Выберите нужную комнату(ы), затем ОК.

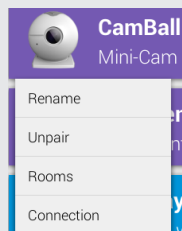

RU



Подключение с помощью вашего мобильного телефона

Планшетом Smart Home можно управлять, находясь вне дома, используя телефон или планшет.

Загрузка приложения

- 1 Загрузите приложение Archos Home из Play Store или Appstore, либо вставьте QR-код.
- 2 После загрузки запустите программу.

При первом запуске программы есть два варианта подключения к планшету Archos Smart Home.

Подключение, если вы находитесь в одной сети WiFi

- 1 Выберите вариант «**if you are on the same home network than the Archos Home Gateway**» (если вы находитесь в той же домашней сети, что и Archos Home Gateway).



Отобразится сообщение «Looking for the Archos Home Gateways in your local network» (Поиск Archos Home Gateways в вашей локальной сети). Как только планшет Archos Home обнаружится в вашей сети, вы получите сообщение.

Нажмите для подключения.



Запрос на привязку посылается на Home Tablet.

Выберите **Allow (Разрешить)** на Home Tablet, чтобы авторизовать устройство.

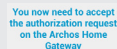

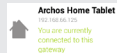

Устанавливается соединение. Когда ваше устройство подключено к Home Tablet, вы можете управлять своим домашним планшетом откуда угодно.



276 Подключение через сеть 3G, либо другую сеть WiFi

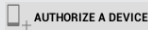
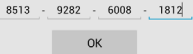
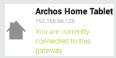

1	Выберите вариант «If you are on a remote connection» (Если вы подключаетесь удаленно) .	
Будет запрошен код для подключения к Home Tablet.		
2	На домашнем планшете запустите приложение Archos Home и выберите вкладку Connection (Подключение).	
3	Во вкладке Connection (Подключение), выберите Authorize a device (Авторизовать устройство) из строки меню.	
Вам будет представлен 32-значный цифровой код. Он должен быть введен на устройстве, которое пытается подключиться к домашнему планшету.		
4	Введите 32-значный цифровой код в окно запроса.	
Устанавливается соединение. Когда ваше устройство подключено к Home Tablet, вы можете управлять своим домашним планшетом издалека.		



Программы

Когда ваши устройства привязаны к вашему домашнему планшету, вы можете создавать программы. Программа — это действие, запускаемое при срабатывании триггера в запланированный период времени.





Интерфейс программы

- 1 Имя программы
- 2 Триггер — это событие, которое создает последовательность действий
- 3 Продолжительность задает ограничение действия по времени
- 4 Действие является результатом события, приводящего к срабатыванию триггера.
- 5 Расписание задает период активности для последовательности действий.
- 6 Нажмите Save (Сохранить) для утверждения программы или Cancel (Отменить) для остановки ее создания.



ММЫ.
д

Чтобы создать программу

- 1 Запустите приложение Archos Home .
 - 2 В приложении Archos Home выберите вкладку Programs (Программы) .
 - 3 Выберите  в строке меню.
- Появится окно создания программы
- 4 Введите имя.
 - 5  : это может быть расписание, обнаружение, погодные условия.
 - 6  : это может быть уведомление, фотография, видео. Вы можете задать продолжительность действия
 - 7 Определите период времени, когда событие возникает.
 - 8 Выберите **SAVE (СОХРАНИТЬ)**.

Программа создана и активирована.

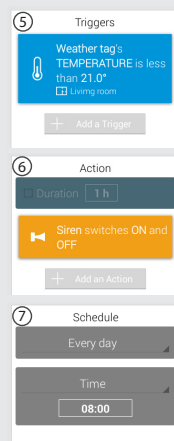

5 Triggers

Weather tag's TEMPERATURE is less than 21.0°
 Living room

+ Add a Trigger

6 Action

Duration | 1 h

Siren switches ON and OFF

+ Add an Action

7 Schedule

Every day

Time

08:00



Check weather

ON

When Weather tag's TEMPERATURE is less than 21.0°
Siren switches ON and OFF
Every day Starts at 08:00



RU

279



Программы

Чтобы изменить программу

- 1 Запустите приложение Archos Home .
 - 2 В приложении Archos Home выберите вкладку Programs (Программы) .
 - 3 Выберите изменяемую программу.
- Для этой программы будут отображены варианты.
- 4 Выберите Edit (Правка).
 - 5 Сделайте необходимые изменения.
 - 6 Выберите **SAVE (СОХРАНИТЬ)**.

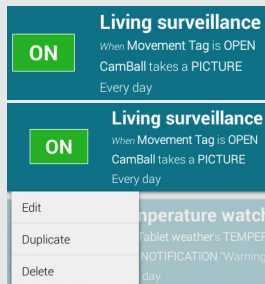



Living surveillance
When Movement Tag is OPEN
CamBall takes a PICTURE
Every day

Living surveillance
When Movement Tag is OPEN
CamBall takes a PICTURE
Every day

Edit temperature watch
Duplicate tablet weather's TEMPER
Delete NOTIFICATION Warning
day

Чтобы включить/выключить программу

- 1 Запустите приложение Archos Home .
- 2 В приложении Archos Home выберите вкладку Programs (Программы) .
- 3 Выберите включаемую программу.
- 4 Нажмите **ON**, чтобы выключить программу **OFF**.

280

Нажмите **OFF**, чтобы опять включить ее **ON**.



Взаимодействие с Archos Home

Ваши устройства привязаны к вашему Home Tablet. Информация с каждого устройства отображается на планшете.



Программы, созданные на вашем планшете, организуют взаимодействие между планшетом и устройствами. Во вкладке Rooms (Комнаты) каждый блок информации соответствует определенному устройству.



RU

Дотроньтесь до блока информации, чтобы отобразить данные из журнала.

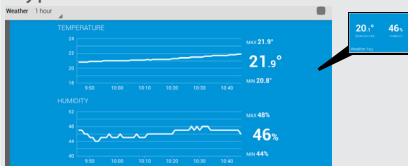

Ваш телефон помогает управлять вашим планшетом и устройствами на расстоянии через программу Archos Home.





Интерфейс Android™

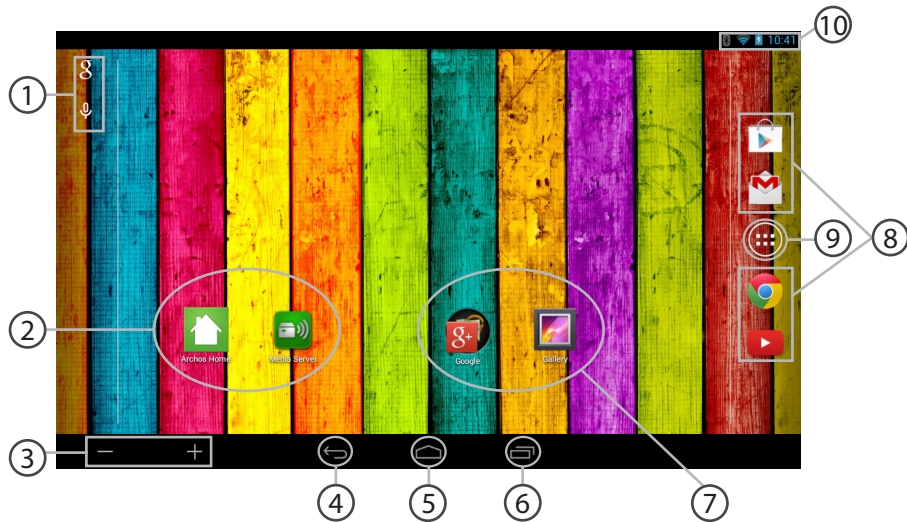



- ① **Поиск Google™**
> Прикоснитесь к позиции «Google», чтобы выполнить тестовый поиск, или к пиктограмме микрофона, чтобы выполнить голосовой поиск.
- ② **Приложения ARCHOS**
- ③ **кнопки регулировки громкости**
- ④ **Кнопка «Назад»**
- ⑤ **Кнопка «Домой»**
- ⑥ **Кнопки последних приложений**
- ⑦ **Ярлыки приложений Google**
> Коснитесь, чтобы запустить приложение.
- ⑧ **Постоянные ярлыки приложений Android™**
- ⑨ **Кнопка «Все приложения»**
> Прикоснитесь к этой пиктограмме, чтобы отобразить все приложения и виджеты, установленные в Вашем ARCHOS. Здесь находятся все загруженные Вами приложения.
- ⑩ **Строка состояния**
> Отображаются сообщения и быстрые настройки.



Интерфейс Android™

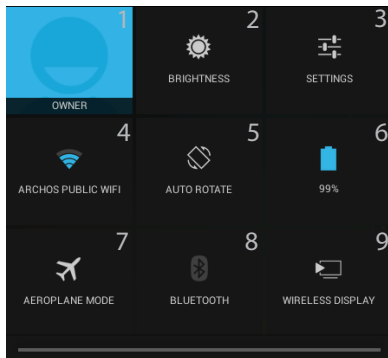

 3:18 Быстрые настройки

- 1 Текущий пользователь⁽¹⁾
- 2 Регулировка яркости экрана.
- 3 Доступ ко всем настройкам.
- 4 Включение/выключение соединения Wi-Fi.
- 5 Активация/деактивация автоматической ориентации экрана при повороте устройства ARCHOS.
- 6 Процентная величина остатка заряда аккумулятора
- 7 Активация/деактивация всех беспроводных соединений, в частности, во время авиаперелета.
- 8 Вы можете отобразить интерфейс Bluetooth
- 9 Включение беспроводной передачи данных⁽²⁾

⁽¹⁾Новая многопользовательская поддержка для планшетов предоставляет различным пользователям свое собственное отдельное, конфигурируемое место на одном устройстве. Добавьте пользователей в Settings > Device [Настройки > Устройство].

⁽²⁾Вы можете смотреть фильмы, видеоролики YouTube и все, что находится на вашем экране, на телевизоре высокой четкости. Чтобы быстро и легко отобразить то, что находится на вашем экране, нужно подключить адаптер беспроводной передачи данных к любому телевизору с мультимедийным интерфейсом высокой четкости (HDMI).



Последние приложения

Открывается список эскизов приложений, с которыми Вы недавно работали:

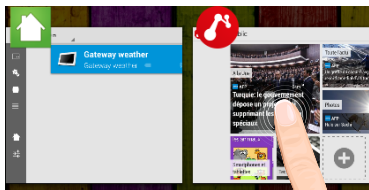

Коснитесь , чтобы открыть приложение.

Удерживание: отображение параметров

RU

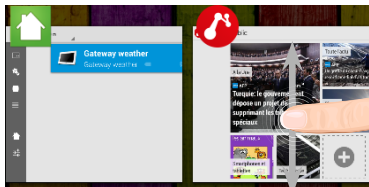

Прокрутка вверх или вниз: закрытие приложения.



Знакомство с Android™

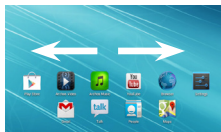

Расширенный домашний экран:

Выполняйте переходы между различными панелями домашнего экрана, смещая их влево и вправо.

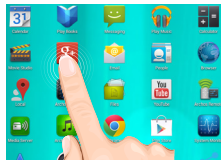

Перемещение элемента домашнего экрана:

Прикоснитесь к элементу и удерживайте палец, пока не появится сетка позиционирования, затем переместите его в требуемое положение, и отпустите палец.

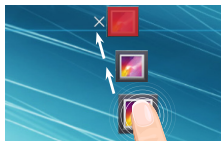

Удаление элемента домашнего экрана:

Прикоснитесь к элементу и удерживая палец, проведите его к верхней части экрана и отпустите над пиктограммой Remove (удалить).



Деинсталляция элемента:

Прикоснитесь к элементу на экране «Все приложения» и удерживая палец, проведите его к верхней части экрана и отпустите над пиктограммой Uninstall (деинсталлировать).

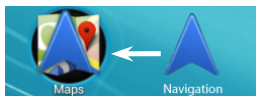

Создание папок приложений:

Поместите пиктограмму одного приложения поверх другого на домашнем экране, и две пиктограммы объединятся.

Виджеты:

Прикоснитесь к пиктограмме «Все приложения» на домашнем экране. Прикоснитесь к позиции Widgets в верхней части экрана. На основном экране Widgets можно переставлять виджеты таким же образом, как пиктограммы приложений.



Изменение обоев:

Удерживайте палец на свободном месте домашнего экрана, затем выберите обои из списка.

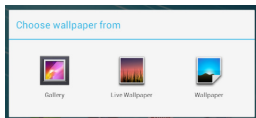

Блокировка сенсорного экрана:

Прикоснитесь к позиции Settings на панели быстрых настроек в строке состояния. На экране Settings выполните прокрутку

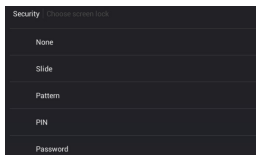

вниз и прикоснитесь к позиции Security (защита). Прикоснитесь к позиции Screen lock (блокировка экрана). Выберите тип блокировки, который хотите использовать. После того, как будет установлена блокировка, при каждом пробуждении экрана будет отображаться экран блокировки с запросом на ввод комбинации символов, PIN-кода или иного указанного ключа.



Устранение неполадок

Что можно сделать, если не работает Bluetooth?

Перейдите в Settings > Wireless & networks (Настройки > Беспроводные и проводные сети), и выберите Bluetooth. Выберите Click (Щелкнуть), чтобы перезапустить Bluetooth.

Bluetooth
Click to restart Bluetooth

Почему я не могу подключиться к своему Home Tablet со своего мобильного телефона?

Возможно, вы подключены к защищенной сети, использующей брандмауэры. В этом случае вы не можете подключиться к своему Home Tablet.

Почему мои устройства не отвечают?

Правильно ли они привязаны к вашему Home Tablet?

Убедитесь в том, что Bluetooth планшета включен.

Убедитесь в том, что батарейки не разрядились. В противном случае необходимо их заменить.

Почему я не могу добавить больше устройств?

Вы не можете привязать более 13 устройств к своему Home Tablet.

Если вы не достигли этого числа, убедитесь в том, что Bluetooth планшета включен, а что батарейки устройств не разрядились.

Каким образом можно вернуть устройство к настройкам по умолчанию?

1. Когда устройство выключено, вставьте вилку блока питания в розетку.
2. Как только загрузочный логотип ARCHOS появится на экране, нажмите кнопку сброса на 5 секунд концом скрепки.

Появится интерфейс восстановления Android.

3. Пальцем выберите вариант.

4. Подтвердите с помощью кнопки ВКЛ/ВЫКЛ.

- Выберите «Wipe data/factory reset» (Стереть информацию/сброс к заводским настройкам) и подтвердите, чтобы вернуть устройство к настройкам по умолчанию.
- Выберите «Yes -- delete all user data» (Да — стереть всю информацию пользователя) и подтвердите, чтобы удалить всю информацию пользователя.
- Выберите «Reboot system now» (Перезагрузить систему сейчас) и подтвердите, чтобы перезагрузить устройство.



National restrictions

This device is intended for home and office use in all EU countries (and other countries following the EU directive 1999/5/EC) without any limitation except for the countries mentioned below:

Country	Restriction	Reason/remark
Bulgaria	None	General authorization required for outdoor use and public service
France	Outdoor use limited to 10 mW e.i.r.p. within the band 2454-2483.5 MHz	Military Radiolocation use. Refarming of the 2.4 GHz band has been ongoing in recent years to allow current relaxed regulation. Full implementation planned 2012
Italy	None	If used outside of own premises, general authorization is required.
Luxembourg	None	General authorization required for network and service supply (not for spectrum)
Norway	Implemented	This subsection does not apply for the geographical area within a radius of 20 km from the centre of Ny-Alesund
Russian Federation	None	Only for indoor applications

Note: Frequency 2454-2483.5MHZ are restricted to indoor use in France.

Consult the declaration of conformity on http://www.archos.com/products/declaration_conformity.html



Open Source Software Offer

The software bundled with this product includes software files subject to certain open source license requirements. Such open source software files are subject solely to the terms of the relevant open source software license. Such open source software is provided on an "AS IS" basis to the maximum extent permitted by applicable law.

For the open source files contained herein, please access "Open source license" section located at: Settings>About tablet\Legal information on the device for the relevant copyright and licensing terms. You may obtain a copy of Apache License, Version 2.0 at <http://www.apache.org/licenses/LICENSE-2.0>. You may also obtain a copy of GNU General Public License, Version 2 at the Free Software Foundation, INC, 51 Franklin Street, Fifth Floor, Boston, MA 02110-1301, USA.

Until the date that is three years after our last shipment of this product, you may obtain a copy of the source code corresponding to the binaries for any GPL-Licensed file by contacting ARCHOS customer service at <http://www.archos.com> and ARCHOS will send you a link to such source code or will provide instructions to get the source on a physical medium.

This offer is valid to anyone in receipt of this information.

CE2200